

# QE CB2R1M12YM4, QE CB2R1M12YM4L

1200 V, 2.1 mΩ, Silicon Carbide, Six-Pack Module

$V_{DS}$	<b>1200 V</b>
$R_{DS(on)}$	<b>2.1 mΩ</b>

## Technical Features

- Fully SiC MOSFET-Based for Ultra-Low Loss
- Comparative Tracking Index (CTI) > 600
- Extremely low Power Loop Inductance (6.6 nH)
- Limited Extended Operation ( $T_{VJ(op)} = 200\text{ °C}$  for 100 h)
- High Performance  $Si_3N_4$  Insulator
- Ultra-Reliable Interconnect Technologies
- True Kelvin Connections for Improved Switching
- Planned AQG 324 Qualification

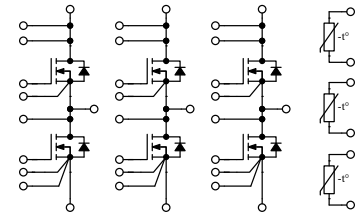
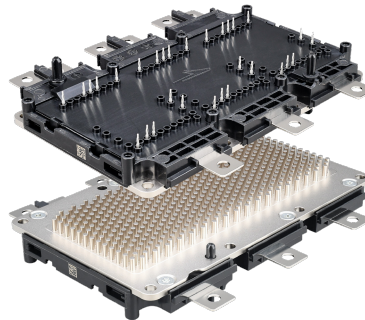

## Typical Applications

- Automotive Traction Inverters
- Commercial, Construction, and Agricultural Vehicles
- Hybrid Electric Vehicles
- E-Mobility and Motor Drives
- Auxiliary Power Supplies
- Renewable Energy

## System Benefits

- Direct-Cooled Pin Fin Baseplate
- Industry-Standard Footprint
- Press-Fit Connection for Ease of Assembly
- Integrated NTC Temperature Sensors
- Option for Long Phase Terminal to Accommodate Current Sensor

## Maximum Parameters (Verified by Design)

Parameter	Symbol	Min.	Typ.	Max.	Unit	Conditions	Note
Drain-Source Voltage	$V_{DS}$			1200			
Gate-Source Voltage, Maximum Value	$V_{GS(max)}$	-8		+19	V	Transient	Notes 1, 2 Fig. 28
Gate-Source Voltage, Recommended	$V_{GS(op)}$		-4/+15			Static	
Implementable Current, Inverter Operation	$I_{IMP}$		650		$A_{RMS}$	$T_F = 65\text{ °C}$ , $F_S = 10\text{ kHz}$	Fig. 18
DC Continuous Drain Current	$I_D$		630		A	$T_F = 25\text{ °C}$	Notes 3, 4 Fig. 17
			540			$T_F = 65\text{ °C}$	
Power Dissipation	$P_D$		1520		W	$T_F = 25\text{ °C}$ , $Q = 10\text{ l/min}$ , $T_{VJ} \leq 185\text{ °C}$	Note 4
Virtual Junction Temperature	$T_{VJ(op)}$	-40		185	°C	Continuous operation	
				200		100 hours over lifetime	

Note (1): Recommended turn-on gate voltage is 15 V with  $\pm 5\%$  regulation tolerance

Note (2):  $V_{GS(op)}$  of +18 V with  $V_{GS(max)}$  of -10/+23 V are permissible for  $T_{VJ} \leq 150\text{ °C}$ . Application note available upon request

Note (3): Current limit calculated by  $I_{D(max)} = \sqrt{(P_D/R_{DS(typ)})(T_{VJ(max)})}$

Note (4):  $P_D = (T_{VJ} - T_F)/R_{th(JF,typ)}$



**MOSFET Characteristics (Per Position) ( $T_{VJ} = 25\text{ °C}$  Unless Otherwise Specified)**

Parameter	Symbol	Min.	Typ.	Max.	Unit	Conditions	Note
Drain-Source Breakdown Voltage	$V_{(BR)DSS}$	1200				$V_{GS} = 0\text{ V}, T_{VJ} = -40\text{ °C}$	
Gate Threshold Voltage	$V_{GS(th)}$	1.8	2.4	3.2	V	$T_{VJ} = 25\text{ °C}$ $T_{VJ} = 185\text{ °C}$ $V_{DS} = V_{GS}, I_D = 122\text{ mA}$	Fig. 10
Zero Gate Voltage Drain Current	$I_{DSS}$		6	60	$\mu\text{A}$	$V_{GS} = 0\text{ V}, V_{DS} = 1200\text{ V}$	
Gate-Source Leakage Current	$I_{GSS}$		60	600	nA	$V_{GS} = 15\text{ V}, V_{DS} = 0\text{ V}$	
Drain-Source On-State Resistance (Devices Only)	$R_{DS(on)}$		2.1	2.6	m $\Omega$	$T_{VJ} = 25\text{ °C}$	Figs. 2, 3
			3.7			$T_{VJ} = 175\text{ °C}$	
			3.9			$T_{VJ} = 185\text{ °C}$	
			4.2			$T_{VJ} = 200\text{ °C}$	
Transconductance	$g_{fs}$		360		S	$T_{VJ} = 25\text{ °C}$ $T_{VJ} = 185\text{ °C}$ $V_{DS} = 20\text{ V}, I_D = 450\text{ A}$	Fig. 4
Turn-On Switching Energy	$E_{ON}$		19.6		mJ	$T_{VJ} = 25\text{ °C}$	Figs. 12, 13, 14, 25, 26
			16.9			$T_{VJ} = 185\text{ °C}$	
			TBD			$T_{VJ} = 200\text{ °C}$	
Turn-Off Switching Energy	$E_{OFF}$		26.0		mJ	$T_{VJ} = 25\text{ °C}$	
			24.7			$T_{VJ} = 185\text{ °C}$	
			TBD			$T_{VJ} = 200\text{ °C}$	
Internal Gate Resistance	$R_{G(int)}$		0.8		$\Omega$	$V_{AC} = 25\text{ mV}, f = 100\text{ kHz}$	
Input Capacitance	$C_{iss}$		39.9		nF	$V_{GS} = 0\text{ V}, V_{DS} = 800\text{ V}, V_{AC} = 25\text{ mV}, f = 100\text{ kHz}$	Fig. 9
Output Capacitance	$C_{oss}$		1.3				
Reverse Transfer Capacitance	$C_{rss}$		61		pF		
Gate to Source Charge	$Q_{GS}$		396		nC	$V_{DS} = 800\text{ V}, V_{GS} = -4\text{ V}/15\text{ V}, I_D = 450\text{ A}, \text{ per IEC60747-8-4}$	
Gate to Drain Charge	$Q_{GD}$		366				
Total Gate Charge	$Q_G$		1452				
Thermal Resistance, Junction to Fluid	$R_{th(JF)}$		0.105		$\text{°C}/\text{W}$	Single switch, $Q = 10\text{ l}/\text{min}, T_F = 60\text{ °C}$	Fig. 16



**Diode Characteristics (Per Position) ( $T_{VJ} = 25\text{ °C}$  Unless Otherwise Specified)**

Parameter	Symbol	Min.	Typ.	Max.	Unit	Conditions	Note
Body Diode Forward Voltage	$V_{SD}$		6.3		V	$T_{VJ} = 25\text{ °C}$	Fig. 7
			5.5			$T_{VJ} = 185\text{ °C}$	
Reverse Recovery Time	$t_{RR}$		TBD		ns	$V_{GS} = -4\text{ V}$ , $I_{SD} = 500\text{ A}$ , $V_R = 800\text{ V}$ $di/dt = \text{TBD A/ns}$ , $T_{VJ} = 185\text{ °C}$	Fig. 27
Reverse Recovery Charge	$Q_{RR}$		TBD		$\mu\text{C}$		
Peak Reverse Recovery Current	$I_{RRM}$		TBD		A		
Reverse Recovery Energy	$E_{RR}$		0.9		mJ	$T_{VJ} = 25\text{ °C}$	Figs. 12, 13, 14
			4.8			$T_{VJ} = 185\text{ °C}$	
			TBD			$T_{VJ} = 200\text{ °C}$	



### Module Physical Characteristics

Parameter	Symbol	Min.	Typ.	Max.	Unit	Conditions	Note
Package Resistance, High-Side	$R_{pkg(HS)}$		0.30		m $\Omega$	$T_F = 25^\circ\text{C}$	Note 5
Package Resistance, Low-Side	$R_{pkg(LS)}$		0.22				
Baseplate Material			Cu+Ni				
Internal Isolator Material			$\text{Si}_3\text{N}_4$			Basic insulation (class 1, IEC 61140)	
Stray Inductance	$L_{stray}$		6.6		nH	Between DC+ and DC-, $f = 10\text{ MHz}$	
Storage Temperature	$T_{stg}$	-40		125	$^\circ\text{C}$		
Weight	W		805		g		
Maximum Pressure in Cooling Circuit	p			2.5	bar		
Mounting Torque	$M_S$	1.8		2.2	N·m	Baseplate, M4 bolts	
		3.6		4.4		Power terminals, M5 bolts	
Case Isolation Voltage	$V_{isol}$	4.2			kV	DC, $t = 1\text{ s}$	
Comparative Tracking Index	CTI	600					
Clearance Distance		4.3			mm	Terminal to terminal	
		4.5				Terminal to heatsink	
Creepage Distance		9.2				Terminal to terminal	
		9.8				Terminal to heatsink	

Note (5): Total effective resistance (per switch position) = MOSFET  $R_{DS(on)}$  + switch position package resistance

### Temperature Sensor (NTC) Characteristics

Parameter	Symbol	Min.	Typ.	Max.	Unit	Conditions	Note
Resistance at 25 $^\circ\text{C}$	$R_{25}$	4.75	5.00	5.25	k $\Omega$	$T_{NTC} = 25^\circ\text{C}$	
Tolerance of $R_{100}$	$\Delta R/R$	-9.22		9.89	%	$T_{NTC} = 100^\circ\text{C}$ , $R_{100} = 493.3\ \Omega$	
Beta Value for 25 $^\circ\text{C}$ to 50 $^\circ\text{C}$	$B_{25/50}$	3307	3375	3443	K		
Beta Value for 25 $^\circ\text{C}$ to 80 $^\circ\text{C}$	$B_{25/80}$	3346	3414	3482			
Beta Value for 25 $^\circ\text{C}$ to 100 $^\circ\text{C}$	$B_{25/100}$	3368	3436	3503			
Maximum Power Dissipation	$P_{25}$		1.4		mW		



Typical Performance

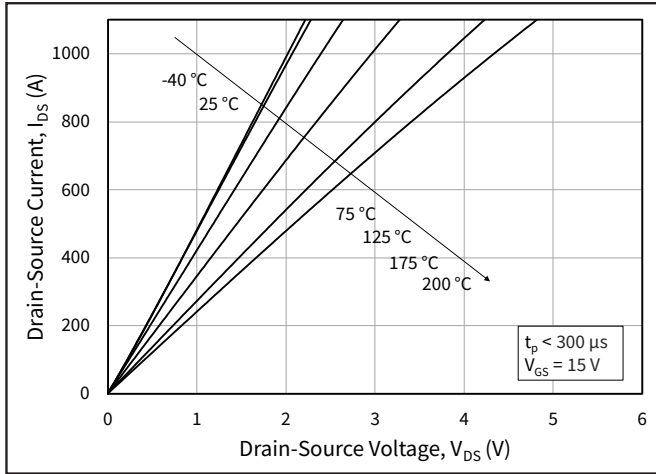

Figure 1. Output Characteristics for Various Junction Temperatures

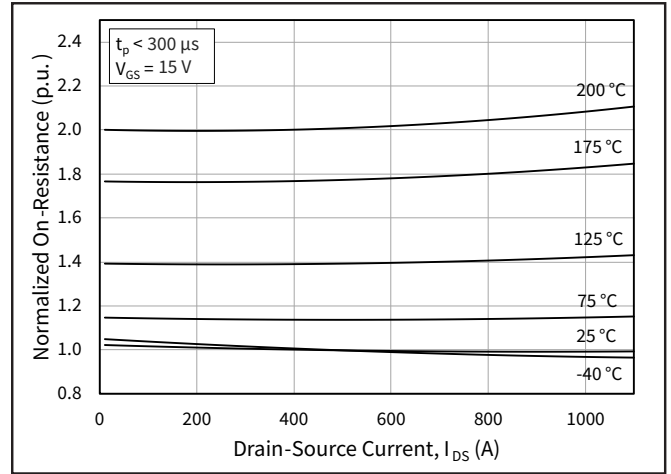

Figure 2. Normalized On-State Resistance vs. Drain Current for Various Junction Temperatures

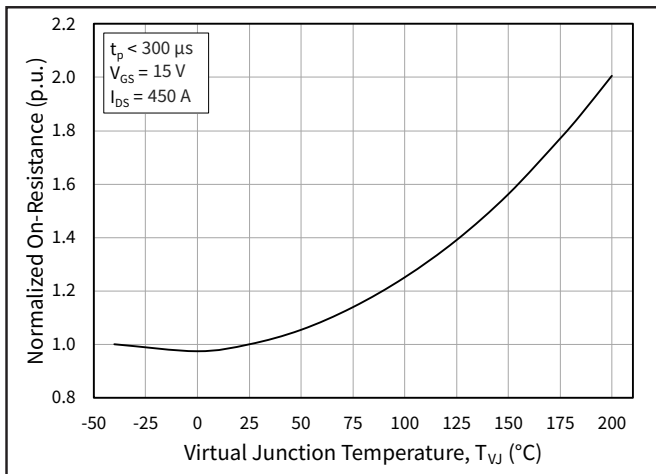

Figure 3. Normalized On-State Resistance vs. Junction Temperature

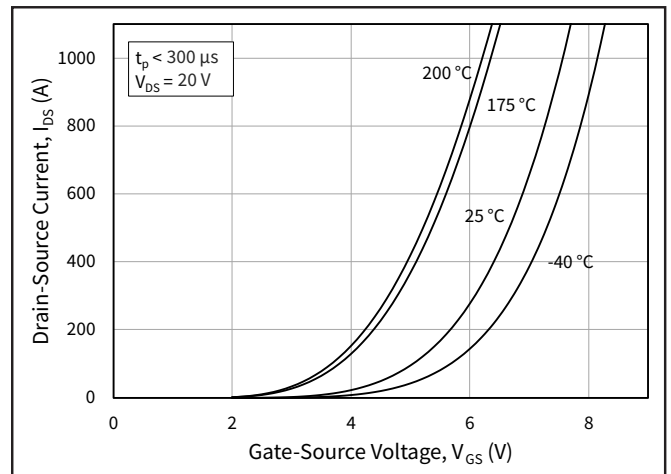

Figure 4. Transfer Characteristic for Various Junction Temperatures

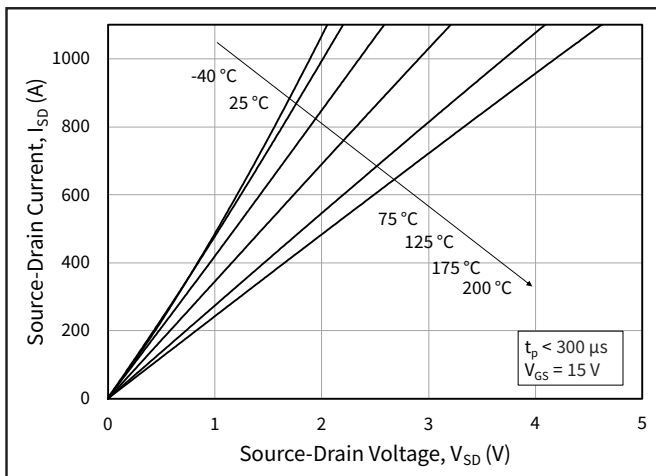

Figure 5. 3<sup>rd</sup> Quadrant Characteristic vs. Junction Temperatures at  $V_{GS} = 15\text{ V}$

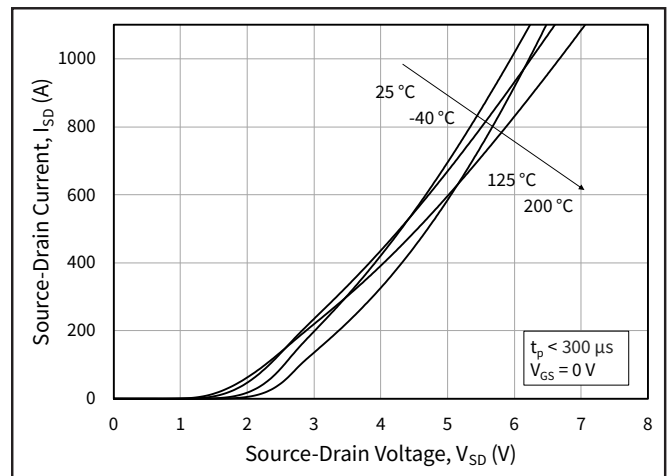

Figure 6. 3<sup>rd</sup> Quadrant Characteristic vs. Junction Temperatures at  $V_{GS} = 0\text{ V}$  (Body Diode)



Typical Performance

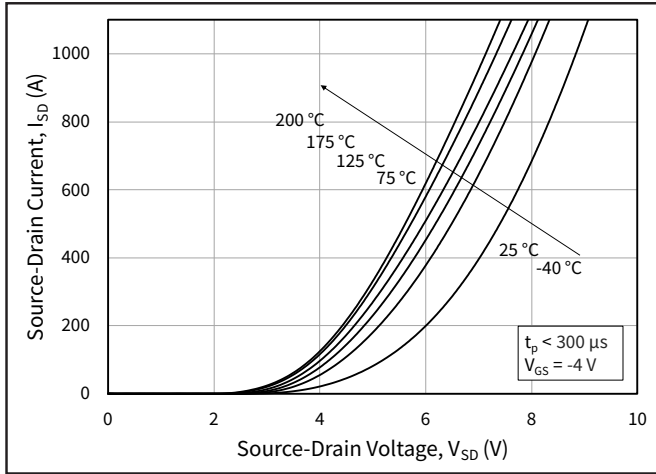

Figure 7. 3<sup>rd</sup> Quadrant Characteristic vs. Junction Temperatures at  $V_{GS} = -4$  V (Body Diode)

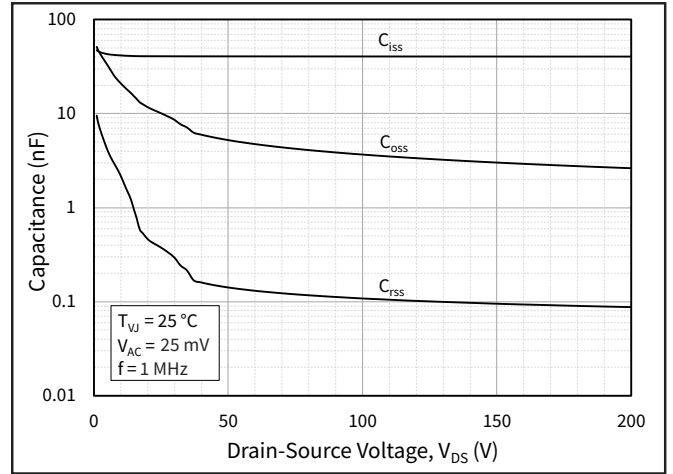

Figure 8. Typical Capacitances vs. Drain to Source Voltage (0 - 200 V)

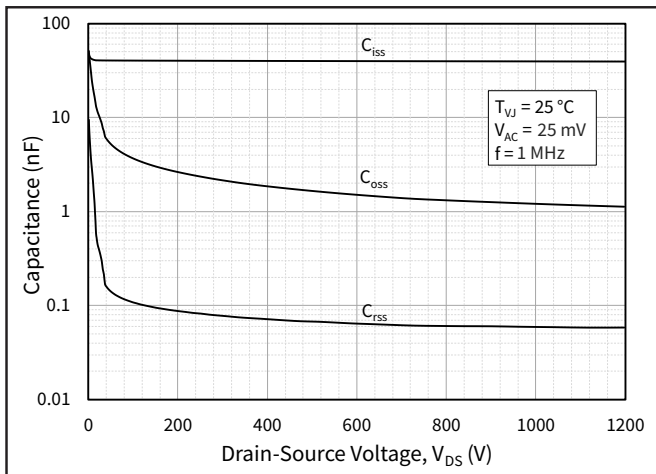

Figure 9. Typical Capacitances vs. Drain to Source Voltage (0 - 1200V)

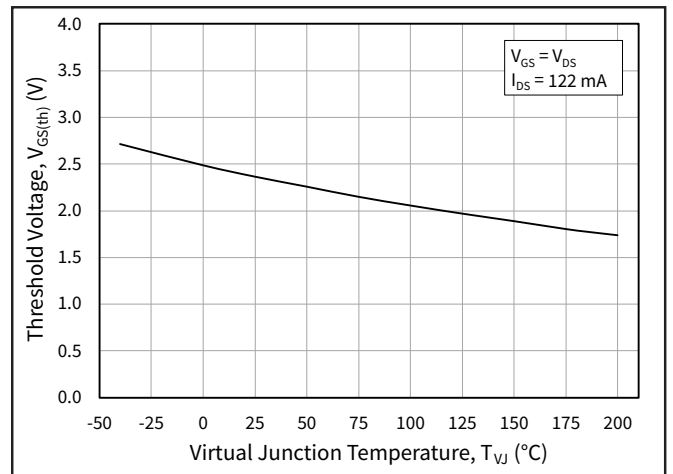

Figure 10. Threshold Voltage vs. Junction Temperature

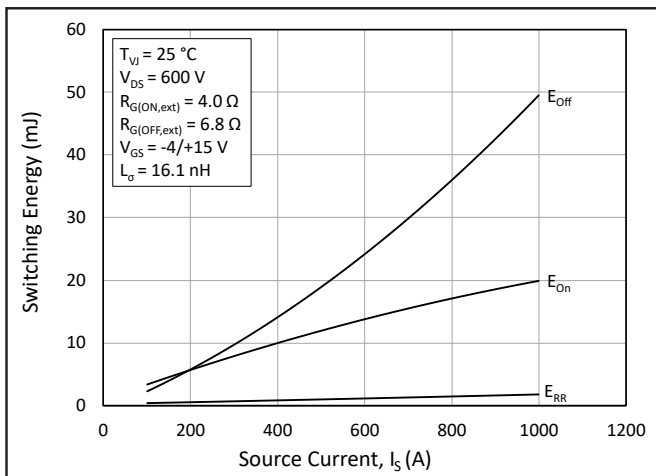

Figure 11. Switching Energy vs. Drain Current ( $V_{DS} = 600$  V)

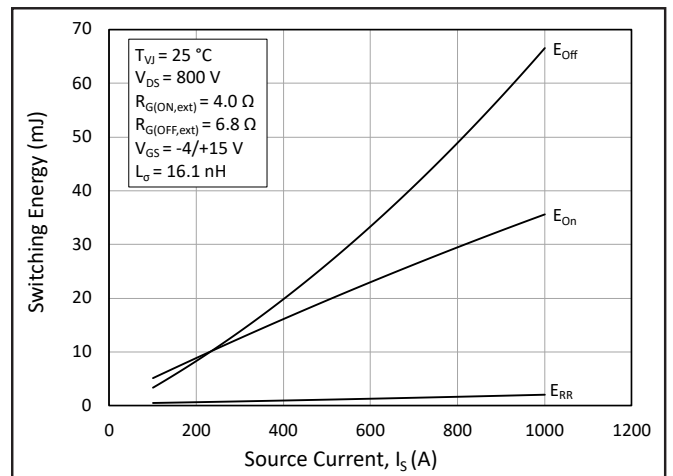
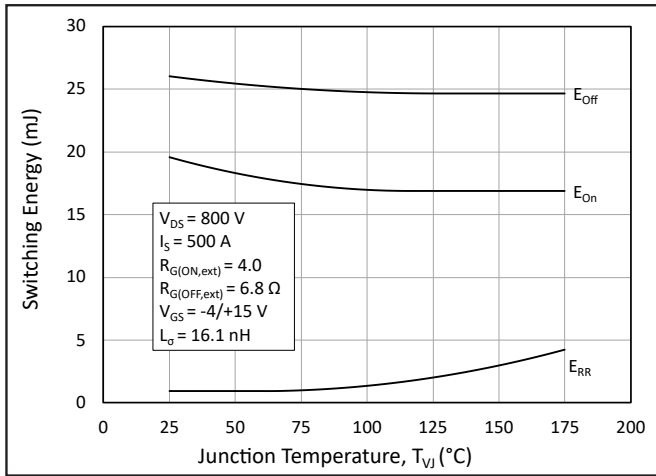

Figure 12. Switching Energy vs. Drain Current ( $V_{DS} = 800$  V)



**Typical Performance**



**Figure 13.** Switching Energy vs. Junction Temperature

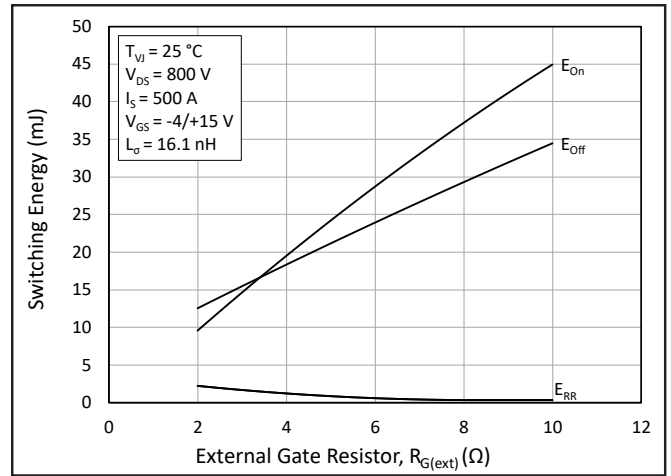

**Figure 14.** Switching Energy vs. External Gate Resistance

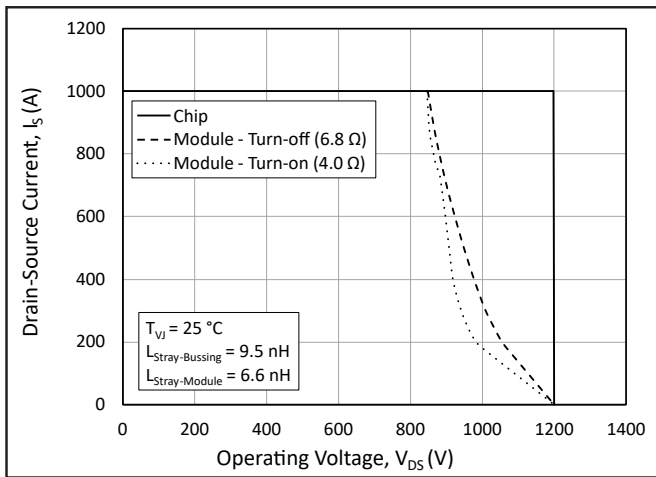

**Figure 15.** Switching Safe Operating Area

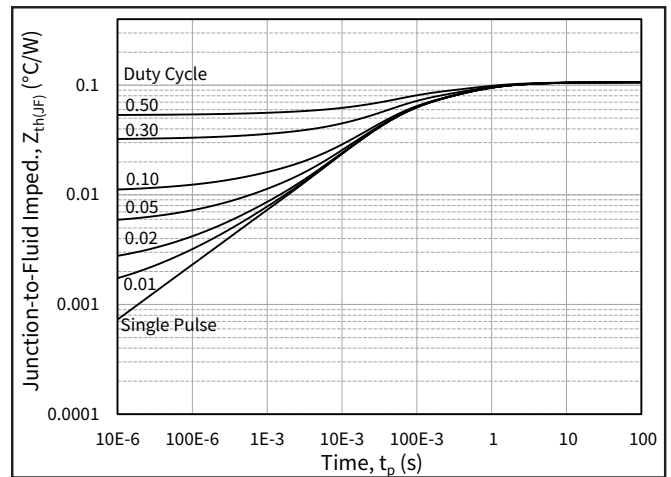

**Figure 16.** Junction to Fluid Transient Thermal Impedance

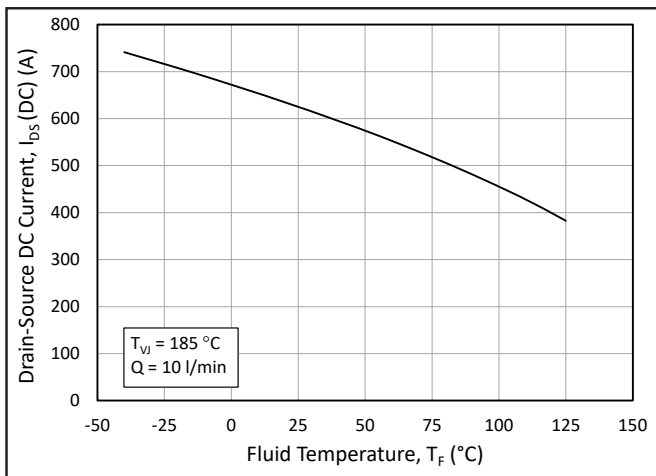

**Figure 17.** Continuous Drain Current Derating vs. Fluid Temperature

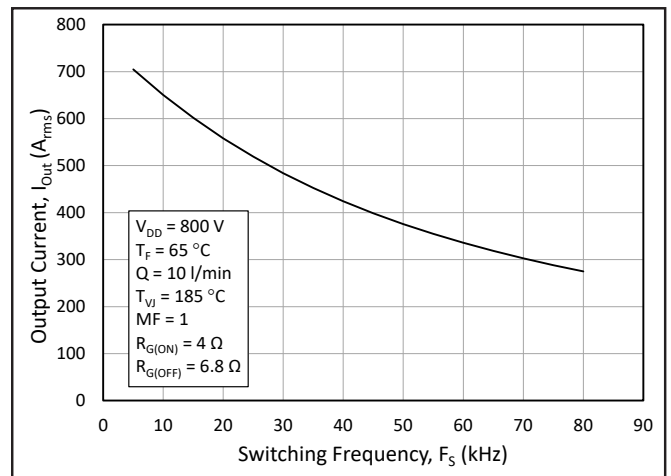

**Figure 18.** Typical Output Current Capability vs. Switching Frequency (Inverter Application)



Typical Performance

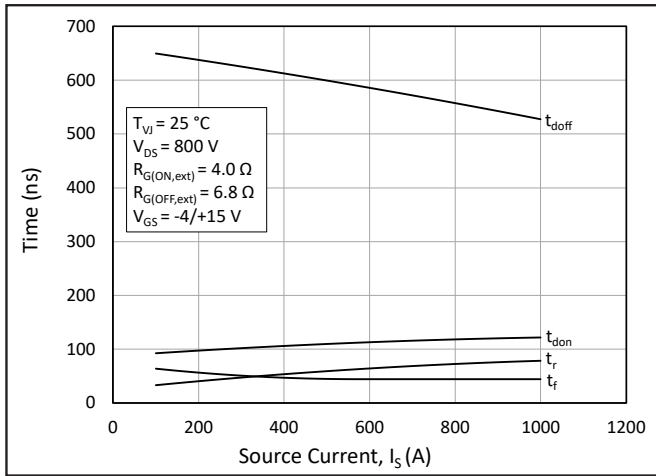

Figure 19. Timing vs. Source Current

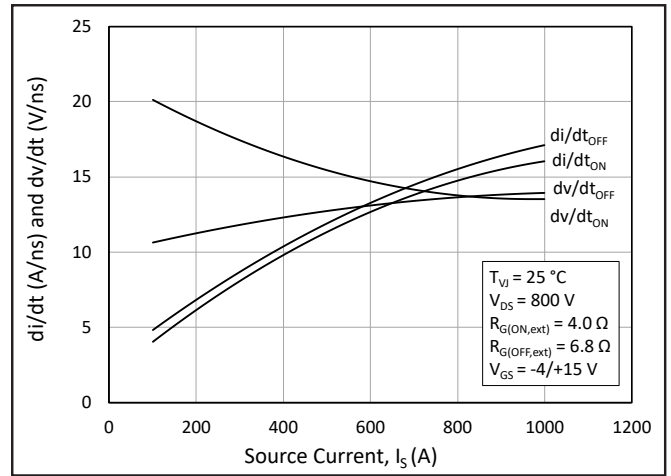

Figure 20.  $dv/dt$  and  $di/dt$  vs. Source Current

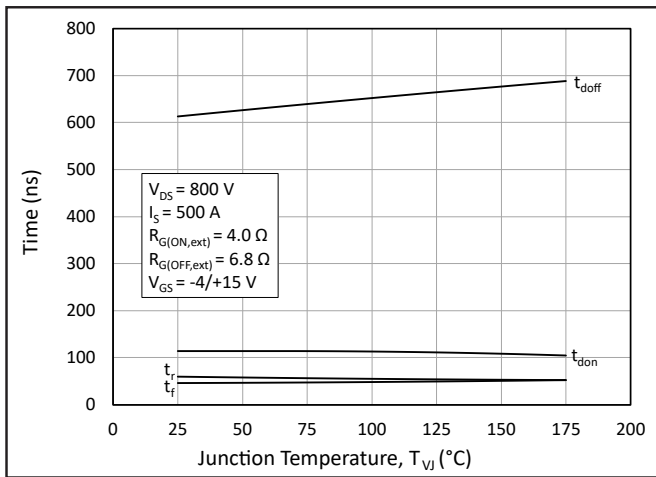

Figure 21. Timing vs. Junction Temperature

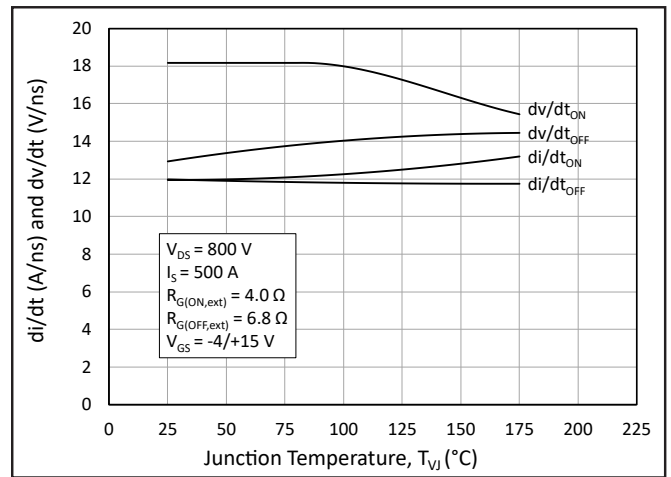

Figure 22.  $dv/dt$  and  $di/dt$  vs. Junction Temperature

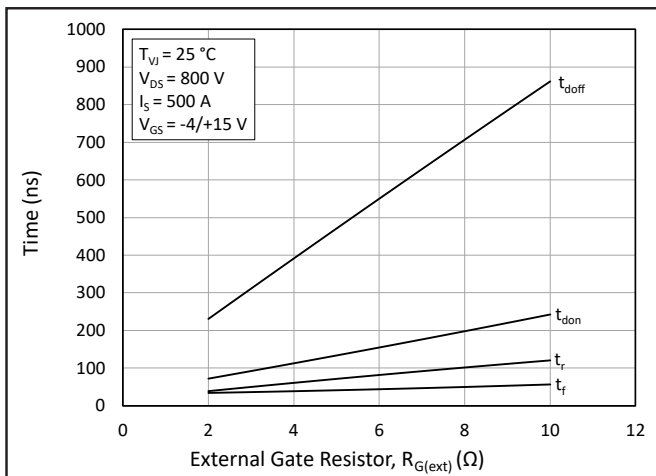

Figure 23. Timing vs. External Gate Resistance

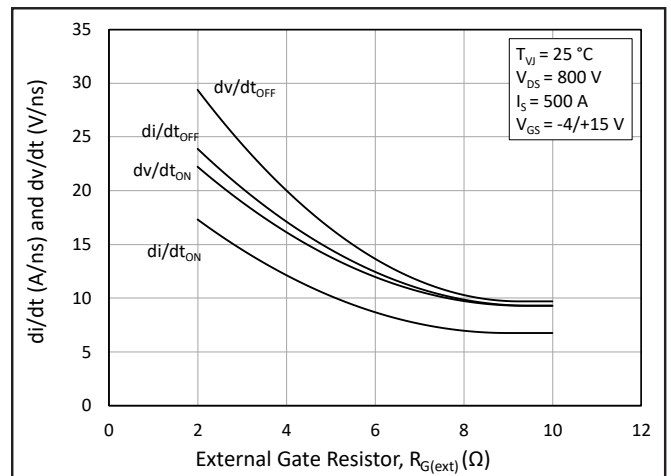
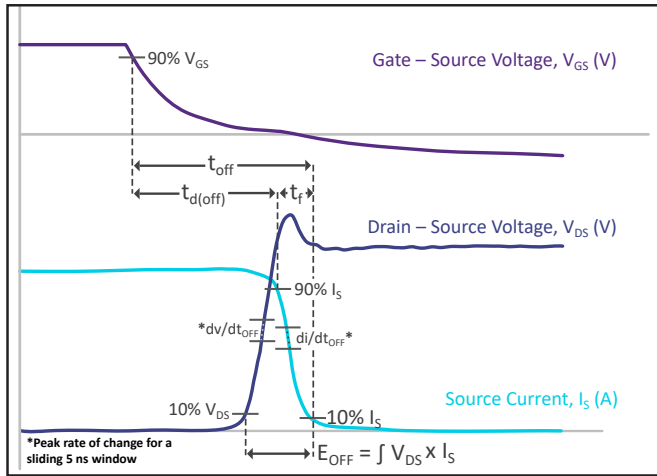
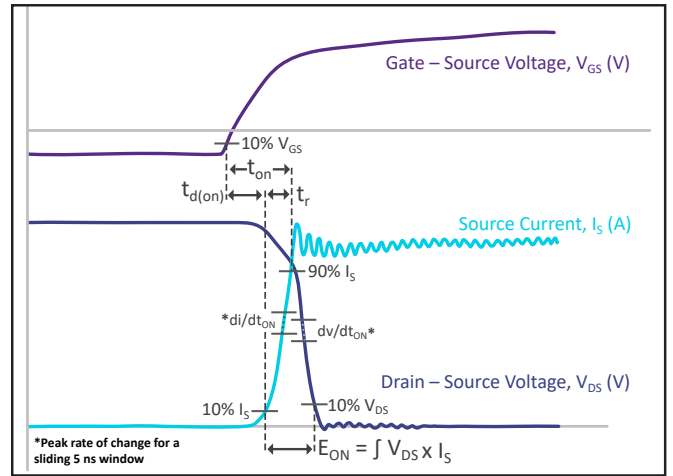

Figure 24.  $dv/dt$  and  $di/dt$  vs. External Gate Resistance

**Definitions**



**Figure 25. Turn-Off Transient Definitions**



**Figure 26. Turn-On Transient Definitions**

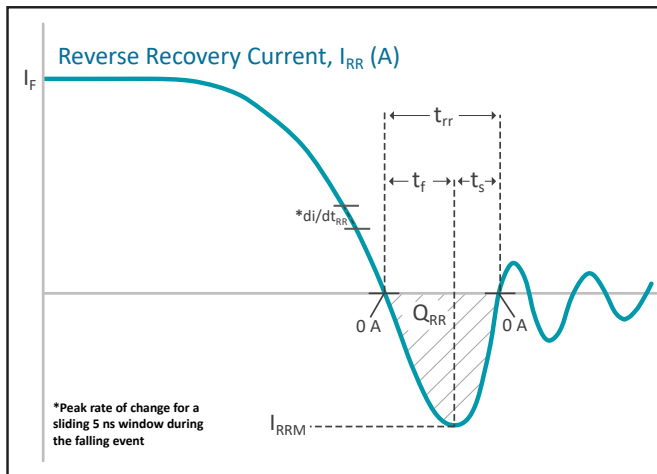

**Figure 27. Reverse Recovery Definitions**

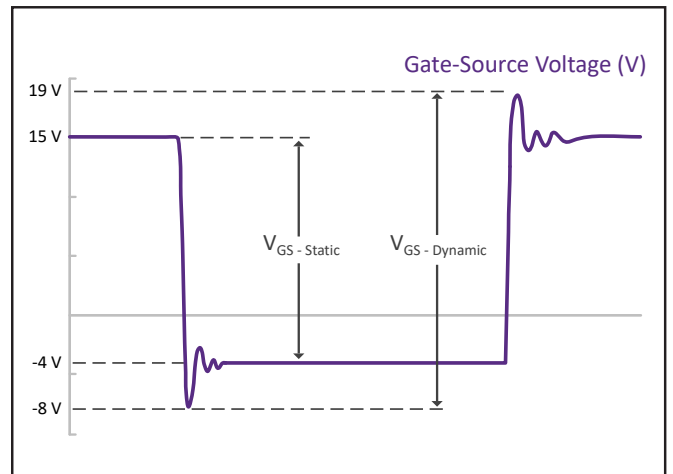
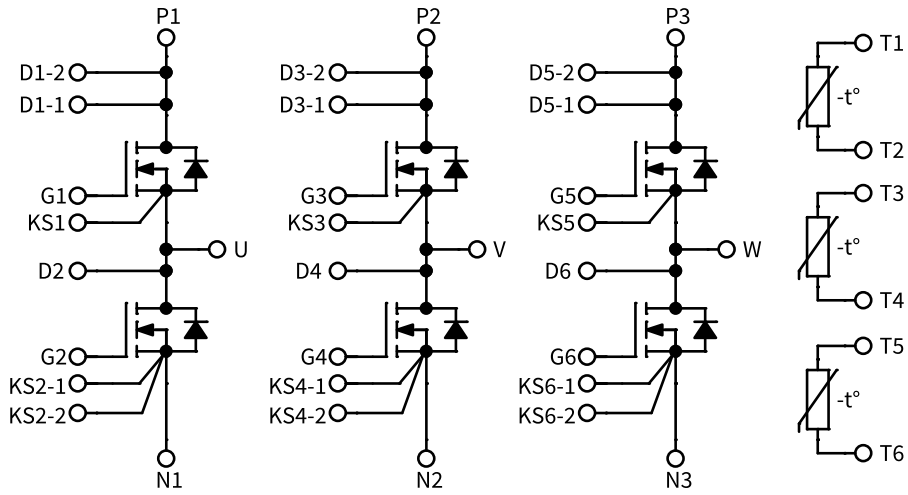

**Figure 28. V<sub>GS</sub> Transient Definitions**

Note: A gate driver featuring the IXDD614SI gate driver IC was used to evaluate dynamic performance. The typical driver high-state output resistance of 0.4 Ω and low-state output resistance of 0.3 Ω are not included in the R<sub>G(ext)</sub> values on this datasheet.



**Schematic and Pin Out**



**Package Dimensions (mm), QECCB2R1M12YM4**

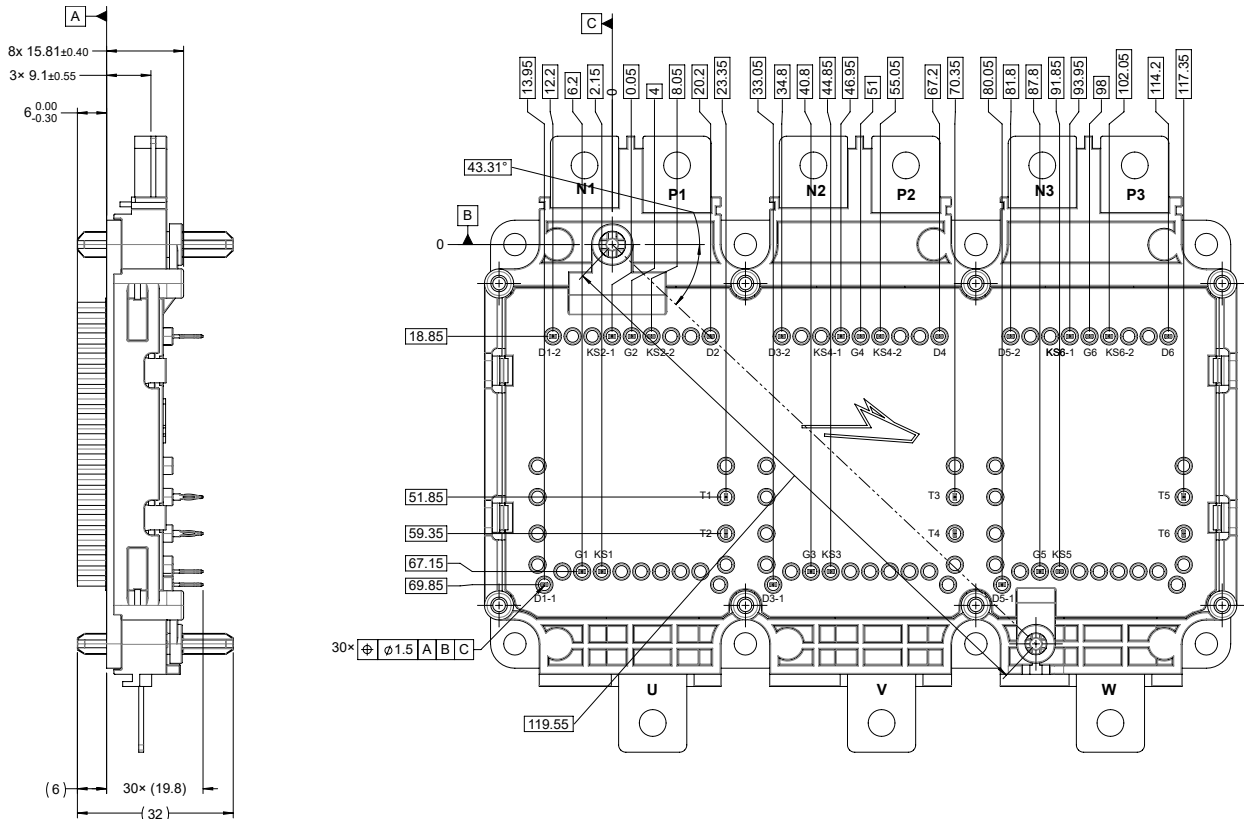
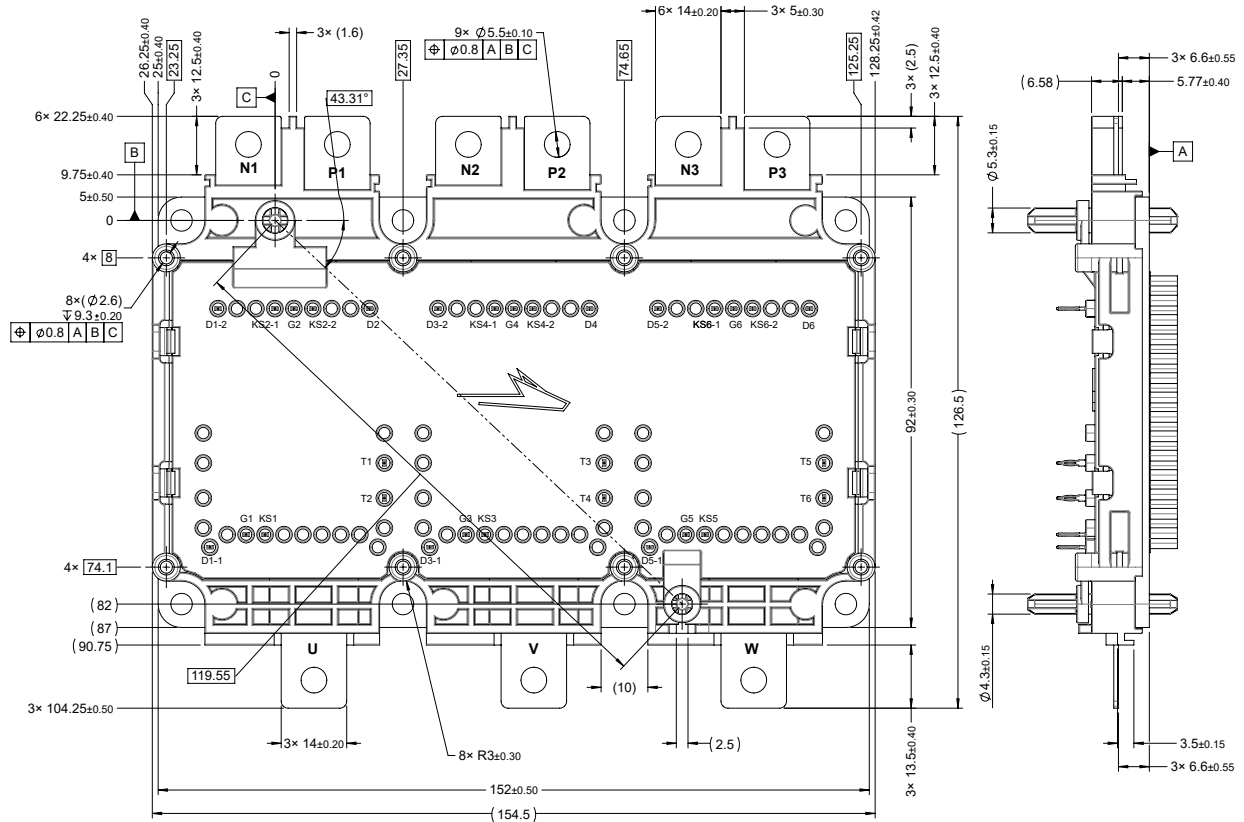

**Package Dimensions (mm), QECB2R1M12YM4, Continued**

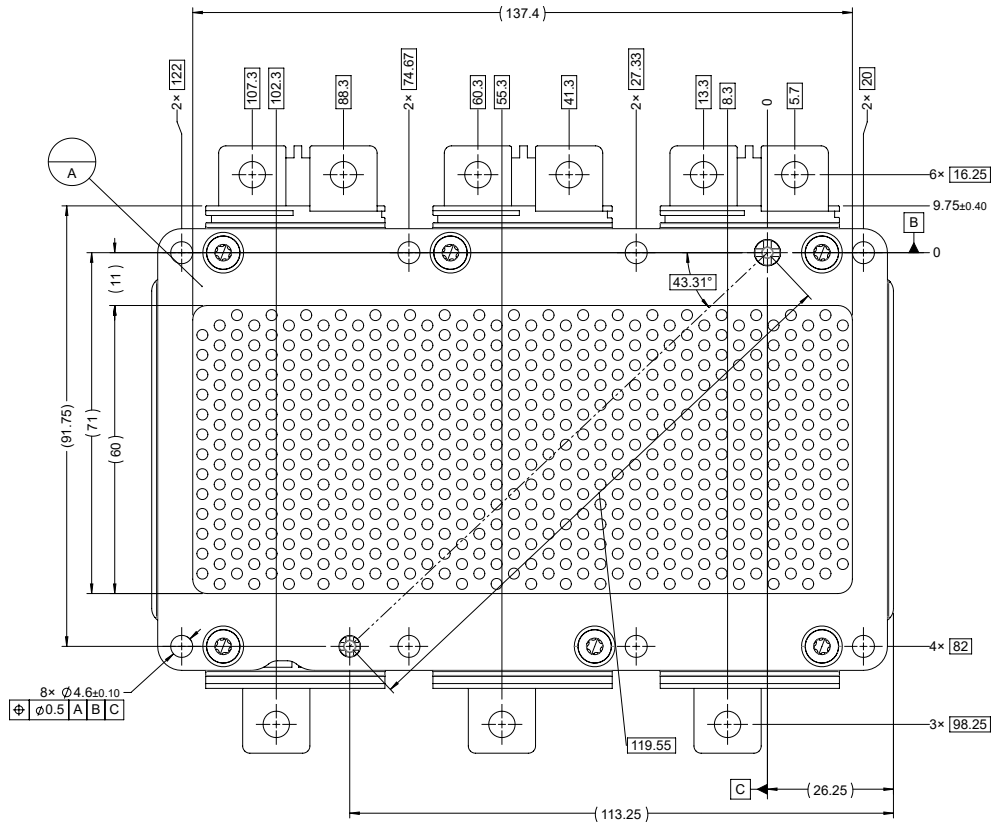

**Package Dimensions (mm), QECCB2R1M12YM4L**

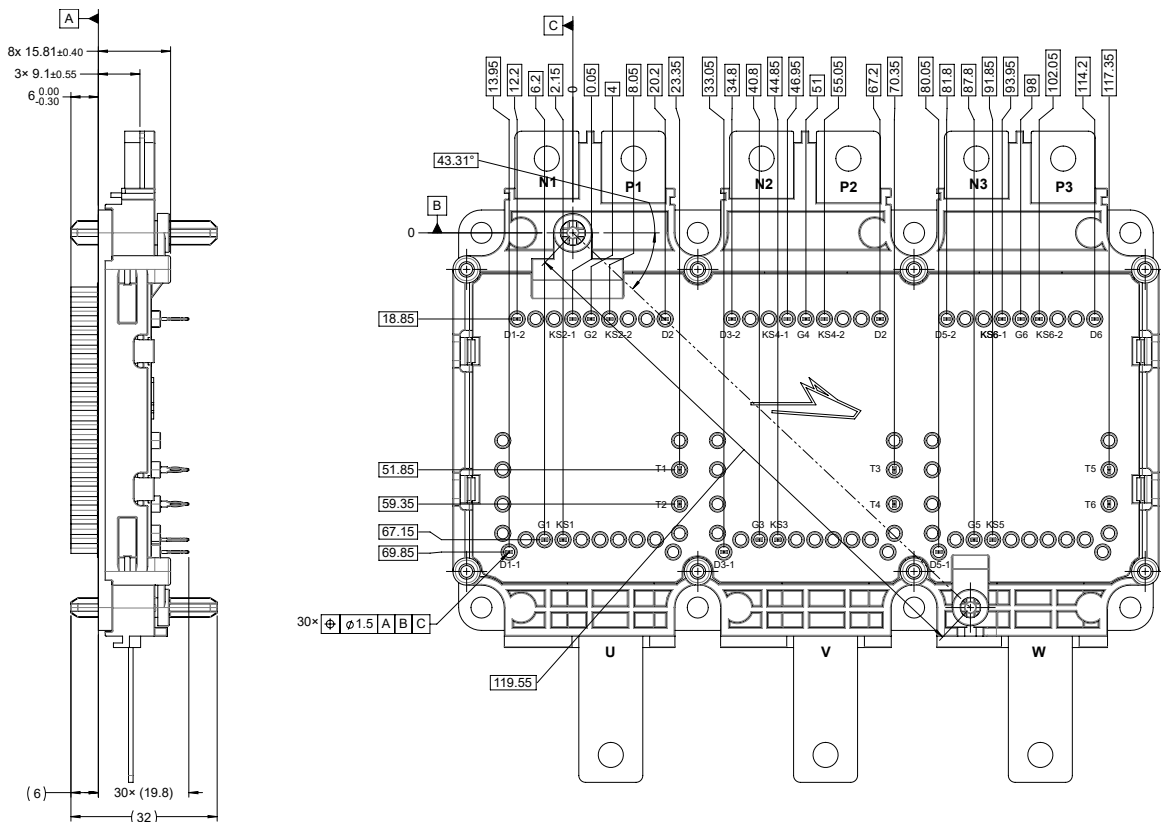
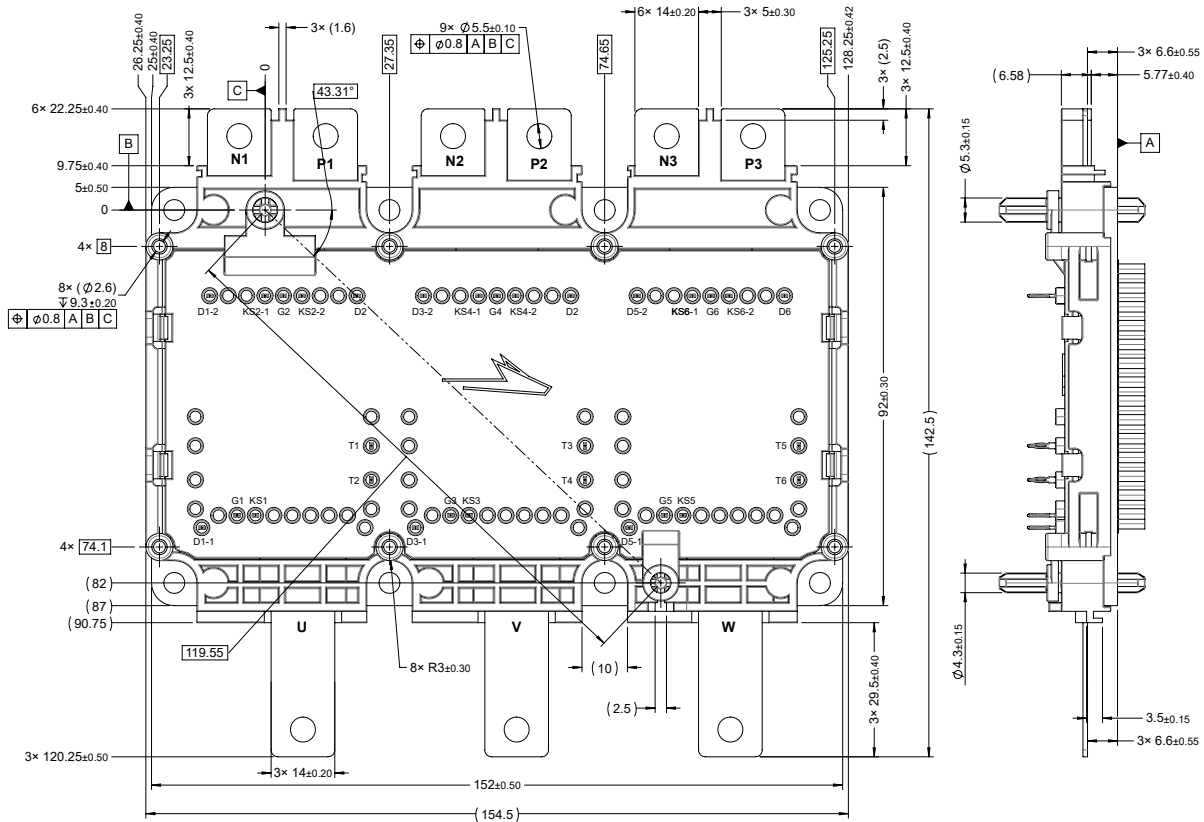





## Product Ordering Code

Part Number	Description
QECB2R1M12YM4	1200 V, 2.1 mΩ, Silicon Carbide, Six-Pack Module, Short Phase Terminal
QECB2R1M12YM4L	1200 V, 2.1 mΩ, Silicon Carbide, Six-Pack Module, Long Phase Terminal

## Revision History

Revision History	Date	Brief Summary
Rev. A	November 2025	Initial prerelease

## Supporting Links & Tools

### Evaluation Tools & Support

- [SpeedFit 2.0 Design Simulator™](#)
- [Technical Support Forum](#)
- [LTspice and PLECS Models](#)
- [KIT-CRD-CIL12N-YMC: Dynamic Performance Evaluation Board for the YM3 Six-pack Module](#)

### Dual-Channel Gate Driver Board

- [CGD12HB00D: Differential Transceiver Daughter Board Companion Tool for Differential Gate Drivers](#)
- [CGD1700HB2M-UNA: Wolfspeed Gate Driver Board](#)
- [EVAL-ADUM4146WHB1Z: Analog Devices® Gate Driver Board](#)
- [UCC21710QDWEVM-054: Texas Instruments® Gate Driver Board](#)
- [NXP EV Traction Inverter Control Reference Design Gen 3](#)

### Application Notes

- [PRD-04814: Design Options for Wolfspeed® Silicon Carbide MOSFET Gate Bias Power Supplies](#)
- [PRD-06379: Environmental Considerations for Power Electronics Systems](#)
- [PRD-08333: Wolfspeed Module CIL Evaluation Kits User Guide](#)
- [PRD-08376: Thermal Characterization Methods and Applications](#)
- [PRD-07845: Power Module Baseplate Capacitance and Electromagnetic Compatibility](#)
- [PRD-08710: Measuring Stray Inductance in Power Electronics Systems](#)
- [PRD-08911: Considerations for Current Balancing in Paralleled SiC Power Modules](#)
- [PRD-09035: Power Module RC Thermal Models User Guide](#)

## Notes & Disclaimers

---

WOLFSPEED PROVIDES TECHNICAL AND RELIABILITY DATA, DESIGN RESOURCES, APPLICATION OR OTHER DESIGN ADVICE, WEB TOOLS, AND OTHER RESOURCES “AS IS” AND WITH ALL FAULTS, AND DISCLAIMS ALL WARRANTIES, EXPRESS AND IMPLIED, WITH RESPECT THERETO, INCLUDING WITHOUT LIMITATION ANY IMPLIED WARRANTIES OF MERCHANTABILITY, SUITABILITY, FITNESS FOR A PARTICULAR PURPOSE, OR NON-INFRINGEMENT OF THIRD-PARTY INTELLECTUAL PROPERTY RIGHTS.

This document and the information contained herein are subject to change without notice. Any such change shall be evidenced by the publication of an updated version of this document by Wolfspeed. No communication from any employee or agent of Wolfspeed or any third party shall effect an amendment or modification of this document. No responsibility is assumed by Wolfspeed for any infringement of patents or other rights of third parties which may result from use of the information contained herein. No license is granted by implication or otherwise under any patent or patent rights of Wolfspeed.

The information contained in this document (excluding examples, as well as figures or values that are labeled as “typical”) constitutes Wolfspeed’s sole published specifications for the subject product. “Typical” parameters are the average values expected by Wolfspeed in large quantities and are provided for informational purposes only. Any examples provided herein have not been produced under conditions intended to replicate any specific end use. Product performance can and does vary due to a number of factors.

This product has not been designed or tested for use in, and is not intended for use in, any application in which failure of the product would reasonably be expected to cause death, personal injury, or property damage. For purposes of (but without limiting) the foregoing, this product is not designed, intended, or authorized for use as a critical component in equipment implanted into the human body, life-support machines, cardiac defibrillators, and similar emergency medical equipment; air traffic control systems; or equipment used in the planning, construction, maintenance, or operation of nuclear facilities. Notwithstanding any application-specific information, guidance, assistance, or support that Wolfspeed may provide, the buyer of this product is solely responsible for determining the suitability of this product for the buyer’s purposes, including without limitation (1) selecting the appropriate Wolfspeed products for the buyer’s application, (2) designing, validating, and testing the buyer’s application, and (3) ensuring the buyer’s application meets applicable standards and any other legal, regulatory, and safety-related requirements.

### **RoHS Compliance**

The levels of RoHS restricted materials in this product are below the maximum concentration values (also referred to as the threshold limits) permitted for such substances, or are used in an exempted application, in accordance with EU Directive 2011/65/EC (RoHS2), as implemented January 2, 2013. RoHS Declarations for this product can be obtained from your Wolfspeed representative or from the Product Documentation sections of [www.wolfspeed.com](http://www.wolfspeed.com).

### **REACH Compliance**

REACH substances of high concern (SVHCs) information is available for this product. Since the European Chemical Agency (ECHA) has published notice of their intent to frequently revise the SVHC listing for the foreseeable future, please contact your Wolfspeed representative to ensure you get the most up-to-date REACH SVHC Declaration. REACH banned substance information (REACH Article 67) is also available upon request.

### **Contact info:**

4600 Silicon Drive  
Durham, NC 27703 USA  
Tel: +1.919.313.5300  
[www.wolfspeed.com/power](http://www.wolfspeed.com/power)