

C3M0120100K Transition Guide

Wolfspeed  SEPTEMBER 2024

900/1000V → 1200V TRANSITION

- Transitioning to 1200V class devices provides:
 - Increased $R_{DS(ON)}$ options
 - Increased package options
 - Improved availability and lead times
 - Broader range of applications supported
 - Increased scalability across power levels
- Comparable 1200V products offer potential drop-in solutions for existing designs

SUGGESTED REPLACEMENT OPTION 1

	C3M0120100K	C3M0075120K	Notes
Status	EOL issued Oct 2024	Active	Already qualified for production on 200mm
$V_{DS\ max}$ (V)	1000	1200	Increased V_{DS} margin
V_{GS} (V)	-4/+15	-4/+15	Compatible gate voltages
I_D (A)	22	31	
$R_{DS(on)}$ (m Ω)	120	75	Significantly reduced conduction losses
C_{oss} (pF)	48	58	
C_{iss}/C_{rss}	138	695	Reduced impact of miller capacitance
Q_G (nC)	22	53	Increased gate drive power
$R_{G(int)}$ (Ω)	13	9	
$R_{\theta JC}$ (C/W)	1.5 (max)	1.1 (max)	Improved thermal impedance
Package	TO-247-4	TO-247-4	Fully Compatible
Pricing			Improved price

This replacement option is best for most designs and will offer improved efficiency and thermal performance for most applications.

All parameters are typical values at 25 °C unless noted

SUGGESTED REPLACEMENT OPTION 2: HIGH F_{SW} APPLICATIONS

	C3M0120100K	C3M0160120K1	Notes
Status	EOL issued Oct 2024	Active	200mm qualification in process. Samples available October 2024, production available December 2024.
$V_{DS\ max}$ (V)	1000	1200	Increased V_{DS} margin
V_{GS} (V)	-4/+15	-4/+15	Compatible gate voltages
I_D (A)	22	17.9	
$R_{DS(ON)}$ (m Ω)	120	160	Increased conduction loss
C_{oss} (pF)	48	31	Reduced output capacitance improves switching speed
C_{iss}/C_{rss}	138	365	Reduced impact of miller capacitance
Q_G (nC)	22	32	Increased gate drive power
$R_{G(int)}$ (Ω)	13	6.5	
$R_{\theta JC}$ (C/W)	1.5 (max)	1.13	Similar thermal impedance
Package	TO-247-4	TO-247-4 LP	See package differences on following slide
Pricing			Competitive price

This option may be suitable for applications that are switching loss dominated.

All parameters are typical values at 25 °C unless noted

K TO K1 PACKAGE COMPARISON

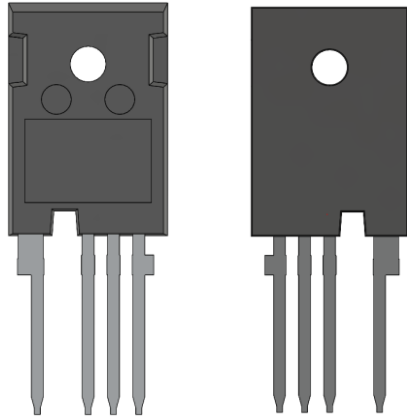

K Package

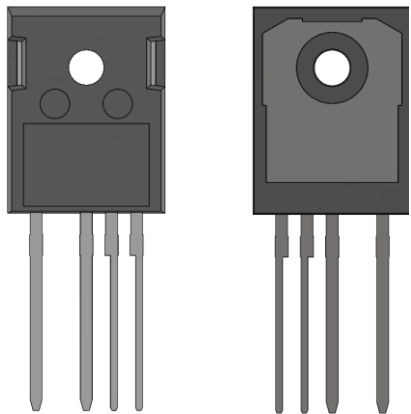
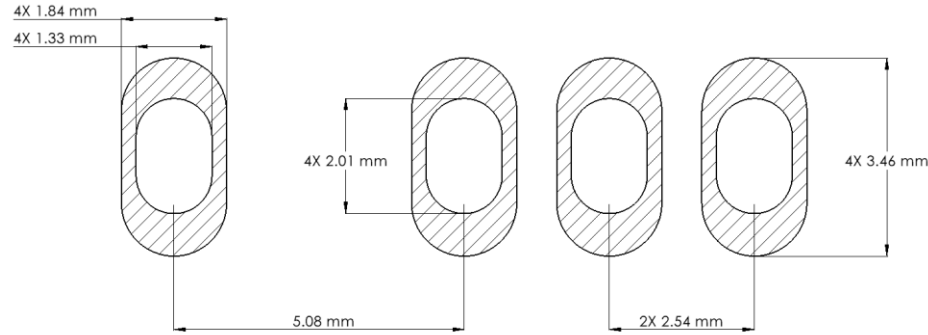

K1 Package

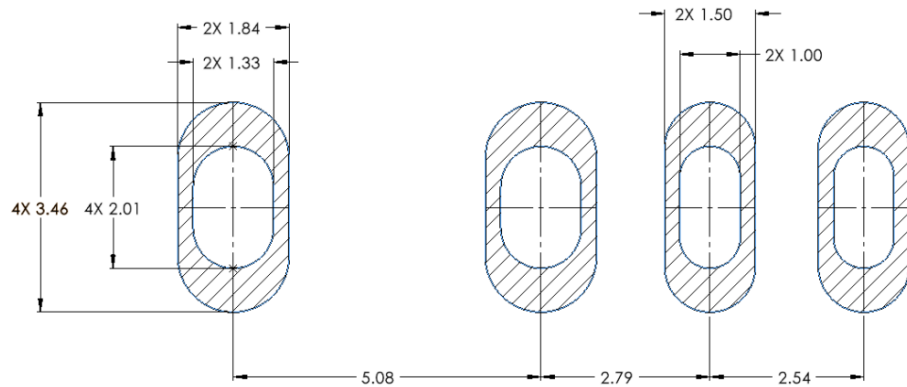

- **K1 package will fit on K solder pad**
- **K package will not fit on K1 solder pad**
- **Due to reduced creepage, K1 may not be suitable for high pollution environments**

Package Creepage Distance All dimensions in mm	K	K1
Pin-to-Pin	10	3.80
Drain tab –Source pin	6.70	5.60

Item All dimensions in mm	K	K1
Device Length	41.00	41.00
Device Width	16.00	16.00
Device Height	5.00	5.00
Lead Length	17.60	20.00
Lead Thickness	0.62	0.62
Drain-Source Lead Spacing	5.08	5.08
Source-Kelvin Lead Spacing	2.54	2.79
Kelvin-Gate Lead Spacing	2.54	2.54

NEXT STEPS

- Samples of recommended replacements available through your [Wolfspeed sales team](#), or at our online [Sample Center](#)
- Ask any technical questions to your Wolfspeed FAE or through our [Power Applications Forum](#)
- Utilize [SpeedFit™](#) to simulate the performance of the recommended replacement devices
 - Keep in mind, dynamic behavior may be different, requiring a different gate resistor value
- The [SpeedVal™ Kit](#) evaluation platform may be utilized to compare the performance and switching behavior

A large, stylized grey graphic of a wolf's head, facing right, serves as a background for the text. The graphic is composed of several overlapping, angular shapes that define the snout, eye, and ear area.

THANK YOU