

Wolfspeed Module CIL Evaluation Kits User Guide

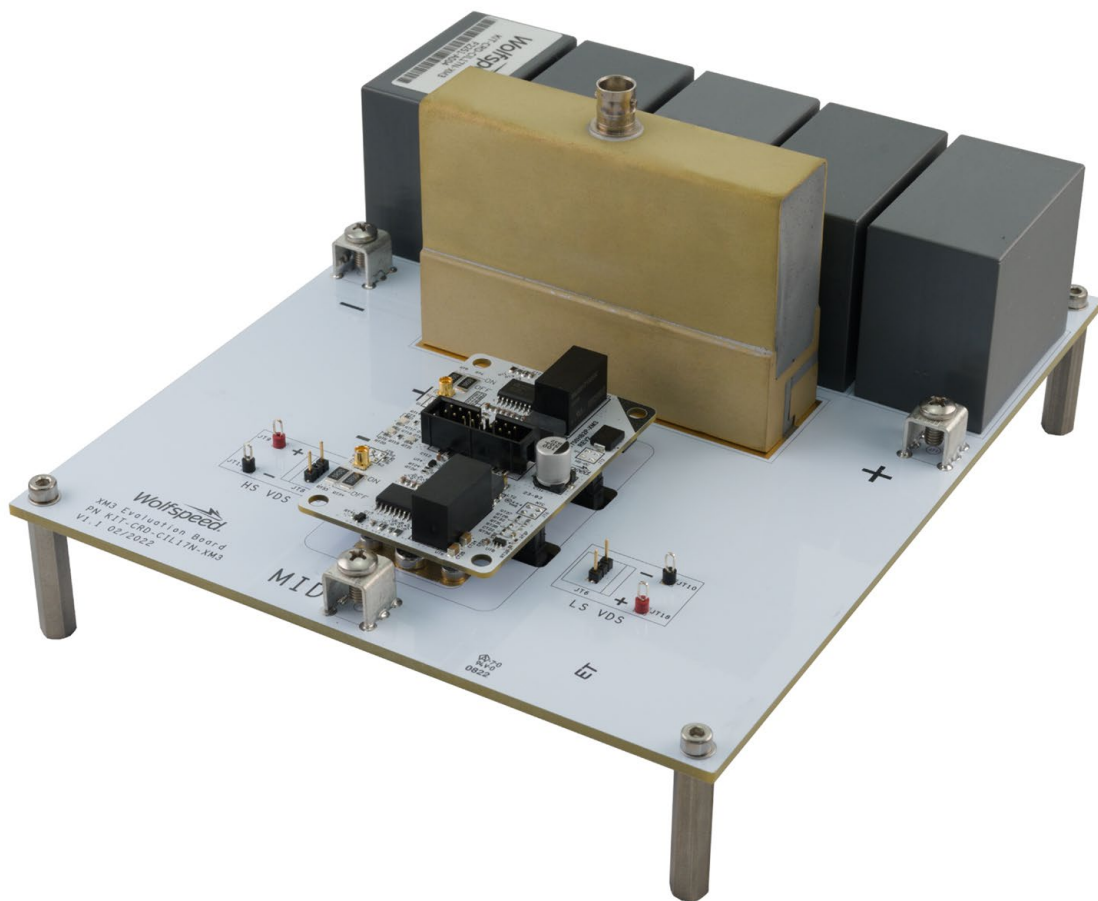

Wolfspeed Module CIL Evaluation Kits User Guide

Double-pulse testing is a useful tool for evaluating the dynamic performance of Wolfspeed™ power modules. However, extracting useful and accurate results requires careful attention to layout and metrology. This document provides guidance on properly operating Wolfspeed CIL evaluation kits to accurately characterize the dynamic behavior of power modules.

Contents

1. Product Scope	7
2. General CIL Overview	7
2.1 Switching Characteristics	7
2.2 Reverse Recovery Characteristics.....	9
2.3 Limitations of CIL Testing	10
3. Evaluation Kits Overview	10
3.1 Load Inductor	11
3.2 Topologies	12
3.2.1 Half-Bridge.....	12
3.2.2 Full-Bridge	13
3.2.3 Six-Pack	14
4. Metrology and Peripheral Configuration.....	15
4.1 Current Sensing Approaches	15
4.1.1 Current Shunt Types	16
4.1.2 CVR Cabling and Termination.....	17
4.1.3 CVR Installation	19
4.2 Drain-Source Voltage Measurements.....	20
4.3 Gate-Source Voltage Measurements	21
4.4 Probe Delay Compensation (Deskew).....	22
4.5 Gate Signal Sequencing	24
4.6 Temperature Setting.....	25
5. Charging and Discharging Sequence.....	26
6. Wolfspeed Evaluation Kits Hardware Overview	28

6.1 KIT-CRD-CIL12N-XM3	29
6.2 KIT-CRD-CIL17N-XM	30
6.3 KIT-CRD-CIL12N-BM	31
6.4 KIT-CRD-CIL17N-BM	32
6.5 KIT-CRD-CIL17N-HM3	33
6.6 Press-Fit Module Notes	34
6.6.1 Gate Driver Mounting	34
6.6.2 Gate-Source Measurements.....	34
6.6.3 NTC Temperature Sensing.....	34
6.6.4 DESAT Terminal.....	35
6.7 KIT-CRD-CIL12N-FMA	35
6.8 KIT-CRD-CIL12N-FMB	36
6.9 KIT-CRD-CIL12N-FMC	37
6.10 KIT-CRD-CIL12N-GMA.....	38
6.11 KIT-CRD-CIL23N-GMA.....	39
6.12 KIT-CRD-CIL17N-DM	40
6.13 KIT-CRD-CIL12N-YMC	41

This document is prepared as a user guide to install and operate Wolfspeed® evaluation hardware.

All parts of this user guide are provided in English, and the Cautions are provided in English, Mandarin, and Japanese. If the end user of this board is not fluent in any of these languages, it is your responsibility to ensure that they understand the terms and conditions described in this document, including without limitation the hazards of and safe operating conditions for this board.

本文件中的所有内容均以英文书写，“注意”部分的内容以英文、中文和日语书写。作为本板子的终端用户，即使您不熟悉上述任何一种语言，您也应当确保正确理解本文件中的条款与条件，包括且不限于本板子的危险隐患以及安全操作条款。

当書類のすべての内容は英語で書きます。「注意点」の内容は英語、中国語、また日本語で書きます。当ボードの端末使用者は上記の言語が一つでもわからないなら、当端末使用者は当書類の条約と条件が理解できるのを確保すべきです。そして、当ボードの危険や安全に使用する条件を含み、また限りません。

Note: This Wolfspeed-designed evaluation hardware for Wolfspeed components is a fragile, high-voltage, high-temperature power electronics system that is meant to be used as an evaluation tool in a lab setting and to be handled and operated by highly qualified technicians or engineers. When this hardware is not in use, it should be stored in an area that has a storage temperature ranging from -40° Celsius to 105° Celsius. If this hardware is transported, to avoid any damage to electronic components, special care should be taken during transportation to avoid damaging the board or its fragile components and the board should be transported carefully in an electrostatic discharge (ESD) bag, or with ESD or shorting protection that is the same as, or similar to, the protection that is or would be used by Wolfspeed when shipping this hardware. Please contact Wolfspeed at <https://forum.wolfspeed.com/> if you have any questions about the protection of this hardware during transportation. The hardware does not contain any hazardous substances, is not designed to meet any industrial, technical, or safety standards or classifications, and is not a production-qualified assembly.

本样机（易碎、高压、高温电力电子系统）由Wolfspeed为评估其功率半导体产品而设计，用以作为在实验室环境下由专业的技术人员或工程师处理和使用的评估工具。本样机不使用时，应存储在-40°~105°温度范围的区域内；如需运输样机，运输过程中应该特别小心，避免损坏电路板等易碎组件。如果您对此硬件在运输之中的保护有任何疑问，请联系<https://forum.wolfspeed.com/>。样机应放置在防静电包装袋内谨慎运输，避免损坏电子组件。本样机不含任何有害物质，但其设计不符合任何工业、技术或安全标准或分类，也不是可用于生产的组件。

このクリーのコンポーネント用評価ハードウェアは壊れやすい高電圧の高温パワーエレクトロニクスシステムであり、ラボ環境での評価ツールとして使用され、優秀な技術者やエンジニアによって処理され、操作されることを意図している。ハードウェアが使用されていない場合、保管温度が-40°Cから105°Cの範囲に保管してください。このハードウェアを輸送する場合は、輸送中にボードまたはその壊れやすいコンポーネントに損傷を与えないよう特別な注意を払う必要がある。また電子部品の損傷を避けるためにボードを静電気放電（ESD）袋に静置して慎重に輸送すべき。ハードウェアの輸送中の保護について質問があれば、<https://forum.wolfspeed.com/>に連絡してください。ハードウェアには危険物質が含まれていないが、工業的、技術的、安全性の基準または分類に適合するように設計されておらず、生産適格組立品でもない。



CAUTION

PLEASE CAREFULLY REVIEW THE FOLLOWING PAGES, AS THEY CONTAIN IMPORTANT INFORMATION REGARDING THE HAZARDS AND SAFE OPERATING REQUIREMENTS RELATED TO THE HANDLING AND USE OF THIS BOARD.

DO NOT TOUCH THE BOARD WHEN IT IS ENERGIZED AND ALLOW THE BULK CAPACITORS TO COMPLETELY DISCHARGE PRIOR TO HANDLING THE BOARD. THERE CAN BE VERY HIGH VOLTAGES PRESENT ON THIS EVALUATION BOARD WHEN CONNECTED TO AN ELECTRICAL SOURCE, AND SOME COMPONENTS ON THIS BOARD CAN REACH TEMPERATURES ABOVE 50° CELSIUS. FURTHER, THESE CONDITIONS WILL CONTINUE FOR A SHORT TIME AFTER THE ELECTRICAL SOURCE IS DISCONNECTED UNTIL THE BULK CAPACITORS ARE FULLY DISCHARGED.

Please ensure that appropriate safety procedures are followed when operating this board, as any of the following can occur if you handle or use this board without following proper safety precautions:

DEATH ▲ SERIOUS INJURY ▲ ELECTROCUTION ▲ ELECTRICAL SHOCK ▲ ELECTRICAL BURNS ▲ SEVERE HEAT BURNS

You must read this document in its entirety before operating this board. It is not necessary for you to touch the board while it is energized. All test and measurement probes or attachments must be attached before the board is energized. You must never leave this board unattended or handle it when energized, and you must always ensure that all bulk capacitors have completely discharged prior to handling the board. Do not change the devices to be tested until the board is disconnected from the electrical source and the bulk capacitors have fully discharged.

警告

请认真阅读以下内容，因为其中包含了处理和使用本板子有关的危险隐患和安全操作要求方面的重要信息。

请勿在通电情况下接触板子，在操作板子前应使大容量电容器的电荷完全释放。接通电源后，该评估板上通常会存在危险的高电压，板子上一些组件的温度可能超过50摄氏度。此外，移除电源后，上述情况可能会短时持续，直至大容量电容器电量完全释放。

操作板子时应确保遵守正确的安全规程，否则可能会出现下列危险：

死亡 ▲ 严重伤害 ▲ 触电 ▲ 电击 ▲ 电灼伤 ▲ 严重的热烧伤

请在操作本板子前完整阅读本文档。通电时禁止接触板子。所有测试与测量探针或附件必须在板子通电前连接。通电时，禁止使板子处于无人看护状态，且禁止操作板子。必须确保在操作板子前，大容量电容器已释放了所有电量。只有在切断板子电源，且大容量电容器完全放电后，才可更换待测试器件。

警告

ボードの使用、危険の対応、そして安全に操作する要求などの大切な情報を含むので、以下の内容をよく読んでください。

通電している時、ボードに接触するのは禁止です。ボードを処分する前に、大容量のコンデンサーで電力を完全に解放すべきです。通電してから、ボードにひどく高い電圧が存在している可能性があります。ボードのモジュールの温度は50度以上になるかもしれません。また、電源を切った後、上記の状況がしばらく持続する可能性がありますので、大容量のコンデンサーで電力を完全に解放するまで待ってください。

ボードを操作するとき、正確な安全ルールを守るのを確保すべきです。さもないと、以下の危険がある可能性があります：

死亡 ▲ 重症 ▲ 感電 ▲ 電撃 ▲ 電気の火傷 ▲ 厳しい火傷

当ボードを操作する前に、完全に当書類をよく読んでください。通電している時にボードに接触する必要がありません。通電する前に必ずすべての試験用のプローブあるいはアクセサリをつないでください。通電している時に無人監視やボードを操作するのは禁止です。ボードを操作する前に、大容量のコンデンサーで電力を完全に解放するのを必ず確保してください。ボードの電源を切った後、また大容量のコンデンサーで電力を完全に解放した後、試験設備を取り換えることができます。



CAUTION

IT IS NOT NECESSARY FOR YOU TO TOUCH THE BOARD WHILE IT IS ENERGIZED. WHEN DEVICES ARE BEING ATTACHED FOR TESTING, THE BOARD MUST BE DISCONNECTED FROM THE ELECTRICAL SOURCE AND ALL BULK CAPACITORS MUST BE FULLY DISCHARGED.

SOME COMPONENTS ON THE BOARD REACH TEMPERATURES ABOVE 50° CELSIUS. THESE CONDITIONS WILL CONTINUE AFTER THE ELECTRICAL SOURCE IS DISCONNECTED UNTIL THE BULK CAPACITORS ARE FULLY DISCHARGED. DO NOT TOUCH THE BOARD WHEN IT IS ENERGIZED AND ALLOW THE BULK CAPACITORS TO COMPLETELY DISCHARGE PRIOR TO HANDLING THE BOARD.

PLEASE ENSURE THAT APPROPRIATE SAFETY PROCEDURES ARE FOLLOWED WHEN OPERATING THIS BOARD AS SERIOUS INJURY, INCLUDING DEATH BY ELECTROCUTION OR SERIOUS INJURY BY ELECTRICAL SHOCK OR ELECTRICAL BURNS, CAN OCCUR IF YOU DO NOT FOLLOW PROPER SAFETY PRECAUTIONS.

警告

通电时不必接触板子。连接器件进行测试时，必须切断板子电源，且大容量电容器必须释放完所有电荷。

板子上一些组件的温度可能超过50摄氏度。移除电源后，上述情况可能会短暂持续，直至大容量电容器完全释放电荷。通电时禁止触摸板子，应在大容量电容器完全释放电荷后，再操作电路板。

请确保在操作电路板时已经遵守了正确的安全规程，否则可能会造成严重伤害，包括触电死亡、电击伤害、或电灼伤。大容量电容器已释放了所有电量。只有在切断板子电源，且大容量电容器完全放电后，才可更换待测试器件。

警告

通電している時にボードに接触する必要がありません。設備をつないで試験する時、必ずボードの電源を切ってください。また、大容量のコンデンサーで電力を完全に釈放してください。

ボードのモジュールの温度は50度以上になるかもしれません。電源を切った後、上記の状況がしばらく持続する可能性がありますので、大容量のコンデンサーで電力を完全に釈放するまで待ってください。通電している時にボードに接触するのは禁止です。大容量のコンデンサーで電力をまだ完全に釈放していない時、ボードを操作しないでください。

ボードを操作している時、正確な安全ルールを守っているのを確保してください。さもなければ、感電、電撃、厳しい火傷などの死傷が出る可能性があります。

1. Product Scope

This user guide supports all Wolfspeed™ case module clamped inductive load (CIL) evaluation kits. The exact products discussed in this document are provided below.

- KIT-CRD-CIL12N-BM
- KIT-CRD-CIL17N-BM
- KIT-CRD-CIL17N-DM
- KIT-CRD-CIL12N-FMA
- KIT-CRD-CIL12N-FMB
- KIT-CRD-CIL12N-FMC
- KIT-CRD-CIL12N-GMA
- KIT-CRD-CIL23N-GMA
- KIT-CRD-CIL12N-HM3
- KIT-CRD-CIL17N-HM3
- KIT-CRD-CIL12N-XM3
- KIT-CRD-CIL17N-XM

2. General CIL Overview

Clamped inductive load circuits (also referred to as double-pulse tests) are useful setups for evaluating the dynamic behavior of switching semiconductors, such as Wolfspeed SiC power modules, without implementing the device in a more complex converter circuit. These circuits can be used to evaluate the active performance of the devices (switching loss) and the inactive performance of the diodes (reverse recovery) with minimal changes in the hardware and configuration. These systems are configured such that the operating voltage, load current, gate resistance, and temperature can be adjusted to measure the dynamic behavior at those specified conditions.

2.1 Switching Characteristics

A general circuit diagram of a CIL circuit for evaluating the switching characteristics of a half-bridge power module is shown in Figure 1 (a), and notional switching waveforms are provided in Figure 1 (b). In this test, the low-side device (Q2) is actively switched and analyzed. The high-side device (Q1) is gated off, and only the body diode is used. A load inductor is placed across Q1 to clamp the load current at the desired operating point. A bulk capacitor, C_{Bulk} , is used to store the energy needed for the test. The “high-frequency” capacitors (C_{HF}) are optional components that can improve the circuit performance by providing a low-inductance path for high-frequency currents. The most critical measurements during operation are the voltages across the gate-source of each switch position (V_{GS-HS} and V_{GS-LS}), the voltages across the drain-source of each switch position (V_{DS-HS} and V_{DS-LS}), and the current through the devices (I_D). The current is measured using a current viewing resistor (CVR).

At the beginning of the test (before T1), Q1 and Q2 are both OFF, and the bulk capacitance, C_{Bulk} , is charged to the desired bus voltage. The capacitance must be large enough to maintain the desired bus voltage throughout the test. At T1, Q1 is turned ON. Current flows from C_{Bulk} , through the load inductor, and through Q2, before returning to C_{Bulk} . During this period, the current will begin increasing at a rate determined by V_{BUS} and the load inductance (a larger load inductor will result in a slower increase in current). At T2, once the target current (I_{TARGET}) is reached, Q2 is turned OFF, and current will freewheel between the diode of Q1 and the load inductor. The switching transition of the waveforms at T2 characterize the “turn-off” switching event. After some time (usually $\sim 3-5 \mu s$), Q2 is turned back ON and the current will again flow through Q2. The switching transition of the waveforms at t3 describe the “turn-on” switching event. After some time (again $\sim 3-5 \mu s$), Q2 is turned OFF and the test is concluded. The duration of the pulses between T2-T3 and T3-T4 must be long enough to allow for any dynamics to settle, but be sufficiently short such that significant energy is not lost in the inductor (for T2-T3) and that the energy dissipation of the device is not too high (for T3-T4).

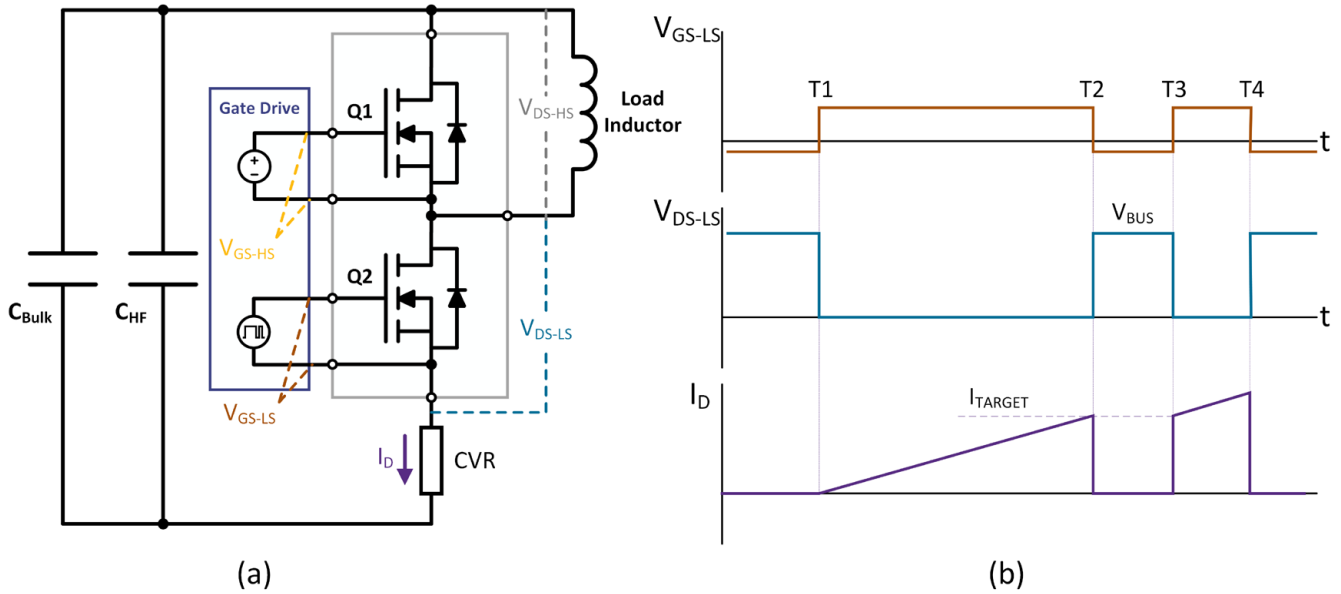

Figure 1: (a) CIL switching test stand circuit and (b) notional test sequence waveforms

Analysis of the measured V_{GS} , V_{DS} , and I_D waveforms allows for the calculation of switching loss energies under precise test conditions to dynamically evaluate the module and facilitate in-module comparisons and power electronic system design. During a CIL switching event, the voltage across and the current through a switch position are simultaneously present. Multiplying these two waveforms point-by-point results in a time-domain function of the instantaneous power in units of Watts (W). The instantaneous power has large peaks two times per switching period at the turn-on and turn-off events. The instantaneous power can then be integrated using built-in oscilloscope MATH tools or waveform data and post processing to determine the total energy lost in Joules (J) during a given switching event. A notional example of this process is shown in Figure 2. The waveforms can also be used to determine overshoots, dead times, and slew-rates.

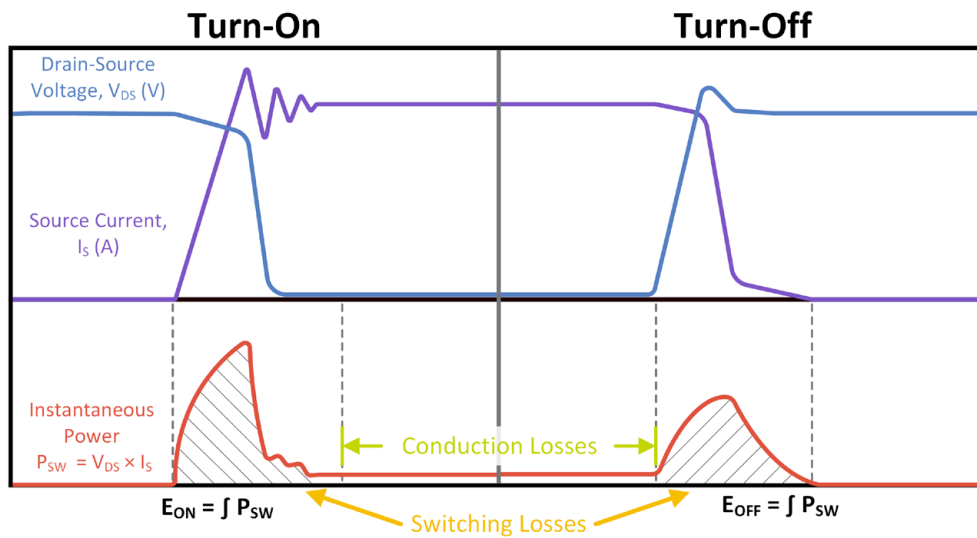

Figure 2: Notional waveforms of forward switching of Q2

2.2 Reverse Recovery Characteristics

A general circuit diagram of a CIL circuit for evaluating the reverse recovery characteristics of a half-bridge power module is shown in Figure 3 (a), and notional waveforms are provided in Figure 3 (b). The circuit configuration differs only by the location of the load inductor (which is now across Q2) and that Q1 is actively switched while Q2 is held off. This change in configuration allows for the body diode of Q2 to be characterized. Note that the load inductor is connected across the CVR. The switching sequence of operation for a reverse recovery test is identical to that of a switching characterization test.

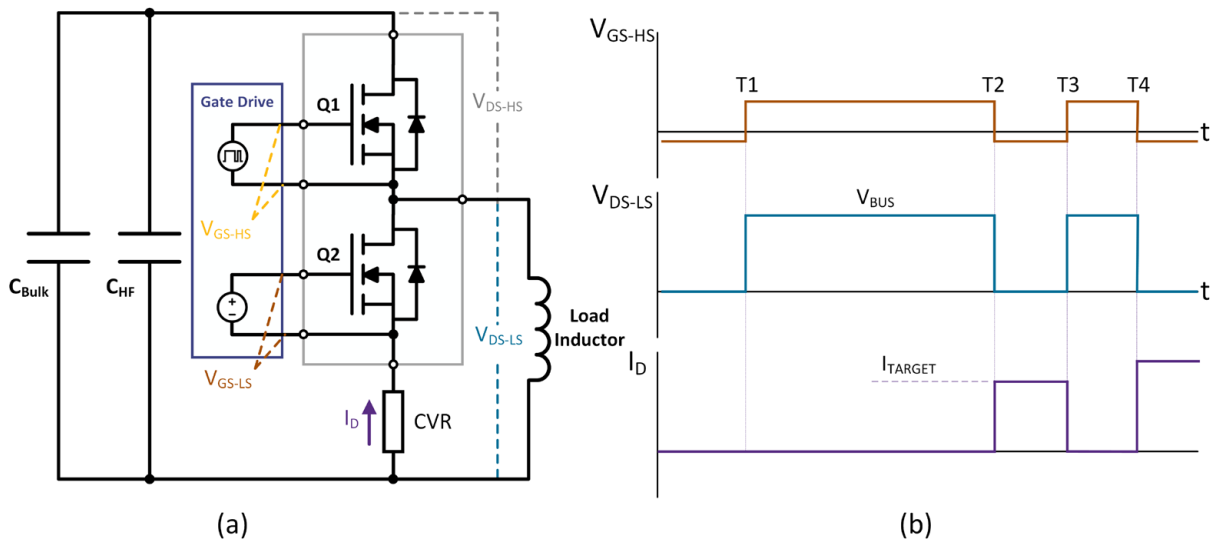

Figure 3: (a) CIL reverse recovery test stand circuit and (b) notional test sequence waveforms

Figure 4 shows notional transient waveforms for the body diode of Q2 at turn-on and turn-off. The forward recovery losses are generally much smaller than the reverse recovery losses and are often ignored. Depending on device temperature and current, the reverse recovery losses at turn-off may be comparable to the losses of the active switch. Due to the forward voltage of the body diode, the conduction losses of the inactive switch can be significant. Actively switching both positions asynchronously can greatly reduce this source of losses.

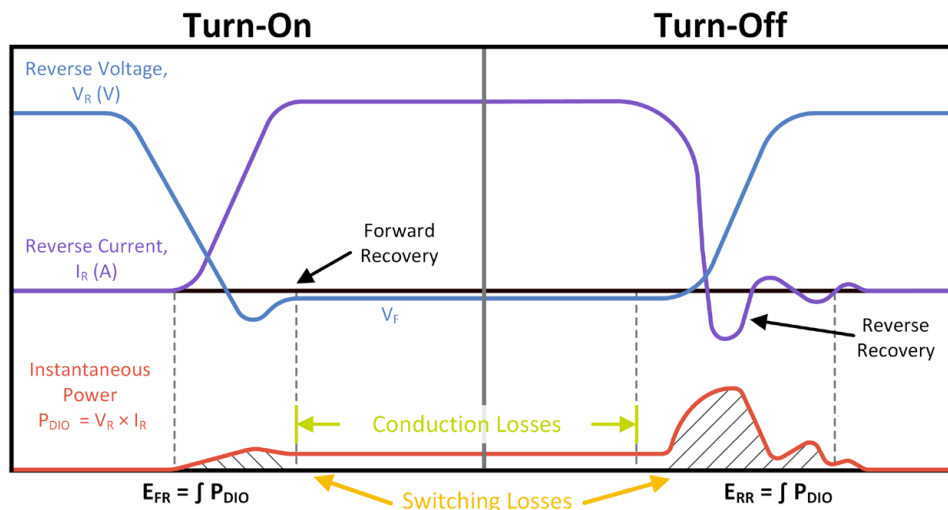

Figure 4: Notional waveforms of Q2 body diode reverse recovery

2.3 Limitations of CIL Testing

CIL testing is useful for evaluating power modules to determine how they will perform in an actual system. However, it is important to understand that the system the module is placed in will have an effect on its performance. For example, the stray inductance of the CIL PCB can affect voltage overshoot, and parasitic capacitance across the board layers or the gate driver output resistance can affect switching speed. In addition, measurements of the high-speed and high-magnitude signals associated with SiC MOSFETs can be challenging, and measurement errors can affect the extracted characteristics. Thus, it is always possible that the module's performance in the final system may differ from what is measured in CIL. To minimize these risks, it is recommended to use Wolfspeed CIL evaluation kits and to follow the metrology guidance outlined in this document. In addition, when possible, it is recommended to monitor the module in the target system to ensure that it lies within the target specifications.

3. Evaluation Kits Overview

An example CIL evaluation kit for half-bridge WolfPACK™ GM modules is shown in Figure 5. All CIL evaluation kits follow the same general layout and structure but will have slight differences to accommodate the module package. All CIL evaluation kits include a bulk capacitor bank located on the PCB, and the load inductor is offboard and connects to the screw terminals. The inductor can be connected to different screw terminals to change between switching characterization and reverse recovery. Refer to section 3.1 for more information on selecting a load inductor. Some CIL evaluation kits also include smaller high-frequency capacitors on the PCB. The two different types of capacitors are utilized to serve different functions. The bulk capacitors located on top of the board serve to provide energy storage for the system. This allows the user to utilize relays/contactors to charge the system up, then physically isolate the power supply from the system and utilize the single ground of the CVR. The capacitors have enough energy storage to provide the inductor current to exercise the system. The smaller, high-frequency capacitors are located on the bottom side of the board underneath the bulk capacitors. These capacitors have much less capacitance but are also physically much smaller in size and therefore have much lower stray inductance. These capacitors serve to minimize the stray inductance of the system at higher frequencies where fast edge rates can cause high di/dt . Without these smaller, lower inductance capacitors, more voltage overshoot will be observed. Low-inductance capacitors are always recommended to minimize stray inductance in the commutation loop, but if these are not permissible for the end application, the CIL evaluation kit can be modified and these capacitors can be removed to determine expected behavior with higher stray inductance.

All CIL evaluation kits include a CVR for current measurements and test points for measuring the switch voltages. Information on how to properly mount the CVR and perform measurements is provided in section 4. Information on test point measurements, DESAT connections, and NTC connections is provided in section 6.

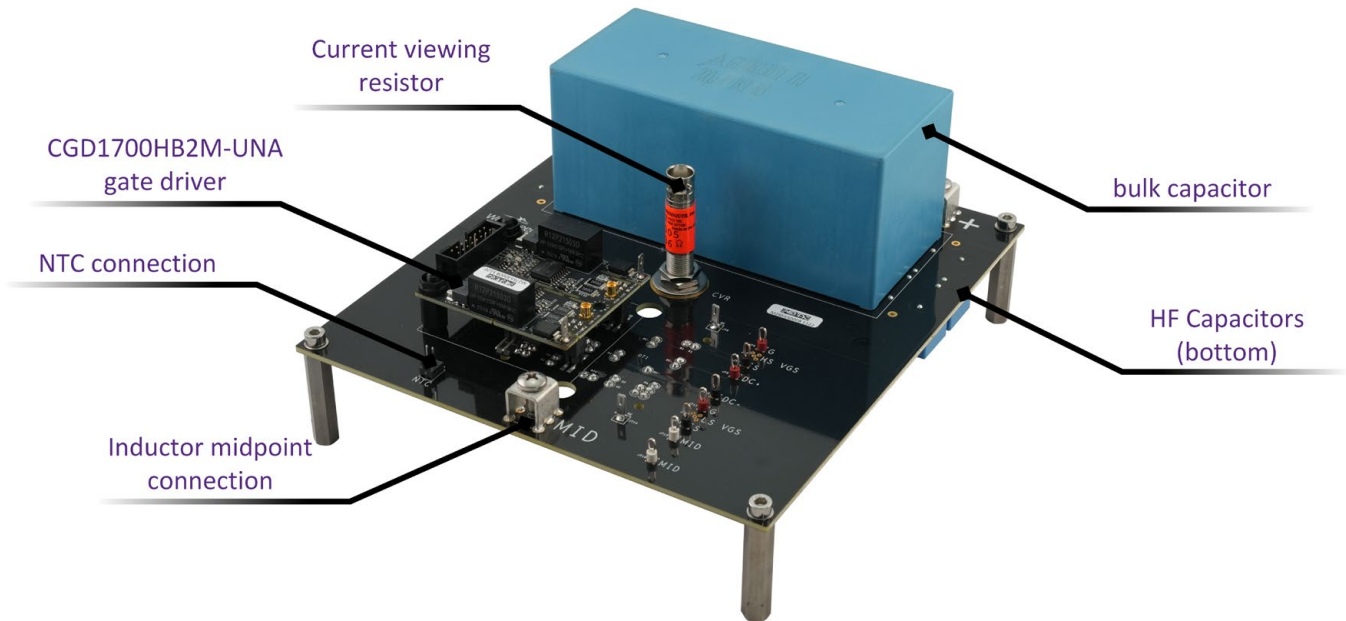

Figure 5: KIT-CRD-CIL12N-GMA CIL evaluation kit

3.1 Load Inductor

The inductor utilized for testing Wolfspeed power modules should be sized to allow enough pulse resolution (5-30 μ s depending on bus voltage) to be able to reach switched current levels in the needed range without running into bandwidth or time resolution issues of the chosen controller that actuates the gate signals. Furthermore, shorter pulse durations keep the oscilloscope's measurement time range small enough (<50 μ s) to achieve the highest sample rate. Oscilloscopes have a limited buffer size, so a large inductor may result in a reduced sample rate due to available memory. Keeping the current pulses short also minimizes the needed on-board bulk energy storage and limits self-heating of the die due to long conduction periods. An air-core inductor can be utilized to prevent saturation and should be shielded to prevent the magnetic field from coupling into any sensitive measurement or control signals. If magnetic core inductors are used, exercise caution as core saturation can result in much higher current levels than expected. A simple method for making an air core inductor for CIL testing is to wind a cylindrical plastic core (such as PVC) with a low-resistance wire. Avoid overlapping the inductor windings; any parasitic capacitance across the load inductor can affect the switching performance of the device. In addition, minimizing the resistance is important to reduce the losses during the freewheeling state.

3.2 Topologies

Wolfspeed CIL evaluation kits are currently available for three topologies: half-bridge, full-bridge, and six-pack. A brief description of the circuit layout for each topology for both switching loss and reverse recovery loss measurements is provided in this section.

3.2.1 Half-Bridge

For half-bridge modules, the test fixtures to measure both events are given below in Figure 6 and Figure 7, respectively. Q1 and Q2 represent the respective switch positions of the Wolfspeed half-bridge power module. Likewise, D1 and D2 represent the intrinsic body diodes of each switch position. Some modules may include embedded Schottky diodes in parallel with the MOSFET. For both tests, film capacitors (C_{BULK}) are used for bulk energy storage to provide the needed energy transfer to the inductor (L) for the switching event, while high-frequency ceramic capacitors (C_{HF}) are used to provide a low-inductance switching loop. For MOSFET switching measurements in Figure 6, the inductor is connected across the upper switch position of the module from the midpoint to the positive bus rail while Q1 is held off and Q2 is pulsed; for body diode switching measurements in Figure 7, the inductor is connected across the lower switch position of the module to the negative bus rail while Q1 is pulsed and Q2 is held off.

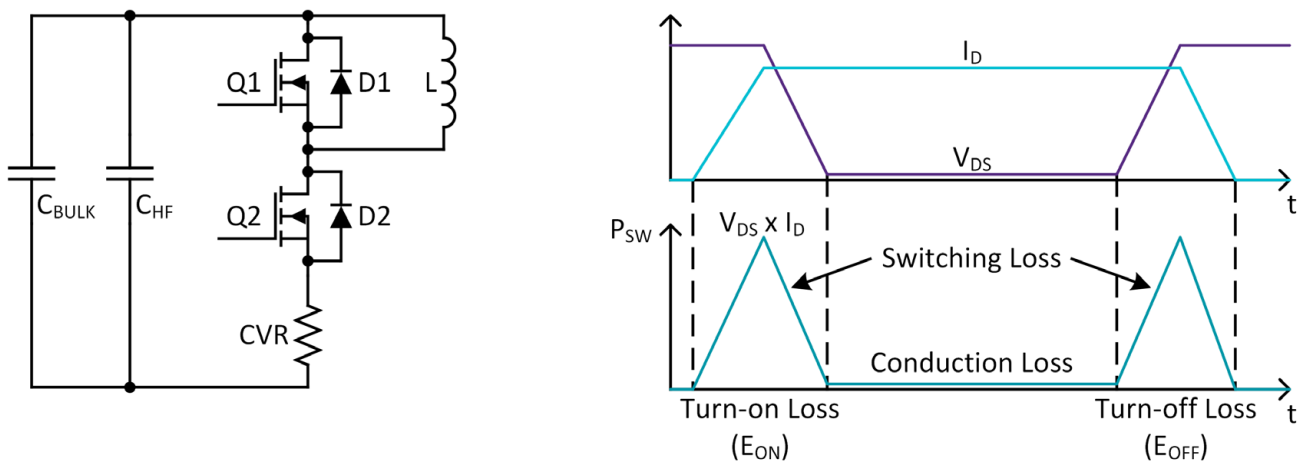

Figure 6: CIL test fixture used to measure the switching loss of MOSFET Q2

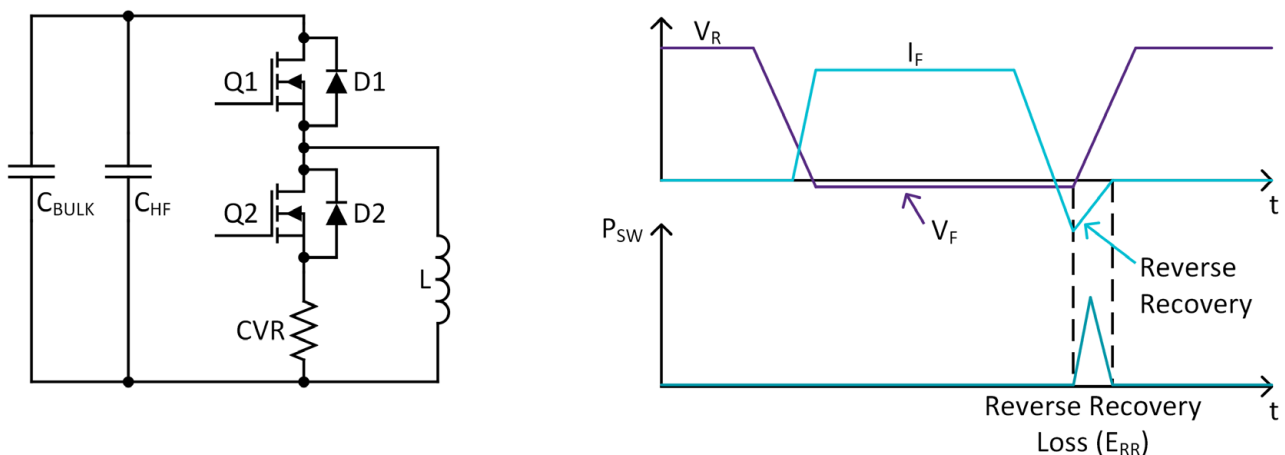

Figure 7: CIL test fixture used to measure the switching loss of body diode D2

3.2.2 Full-Bridge

For full-bridge modules, the test fixtures to measure both events are given below in Figure 8 and Figure 9, respectively, for the “AC2” phase leg. Phase leg “AC1” is inactive in this example and is configured to remain off during testing to avoid affecting the measurements of the active switch positions. Q3 and Q4 represent the selected switch positions of the Wolfspeed full-bridge power module. Likewise, D3 and D4 represent the intrinsic body diodes of each switch position. For both tests, film capacitors (C_{BULK}) are used for bulk energy storage to provide the needed energy transfer to the inductor (L) for the switching event, while high-frequency capacitors (C_{HF}) are used to provide a low-inductance switching loop. For MOSFET switching measurements in Figure 8, the inductor is connected across the upper switch position of the phase leg from the “AC2” midpoint to the positive bus rail while Q3 is held off and Q4 is pulsed; for body diode switching measurements in Figure 9, the inductor is connected across the lower switch position of the phase leg to the negative bus rail while Q3 is pulsed and Q4 is held off.

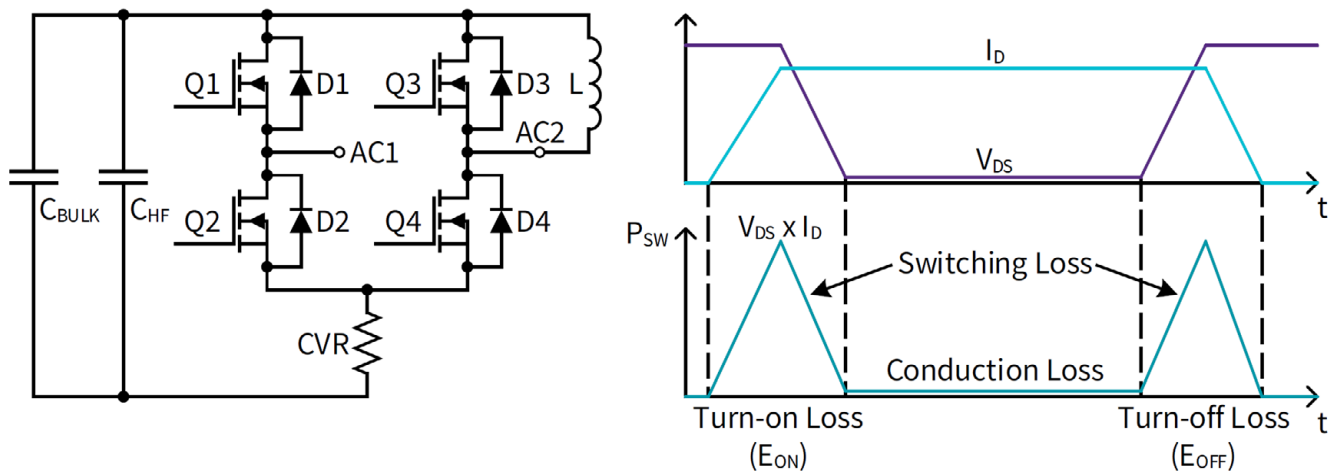

Figure 8: CIL test fixture used to measure the switching loss of MOSFET Q4

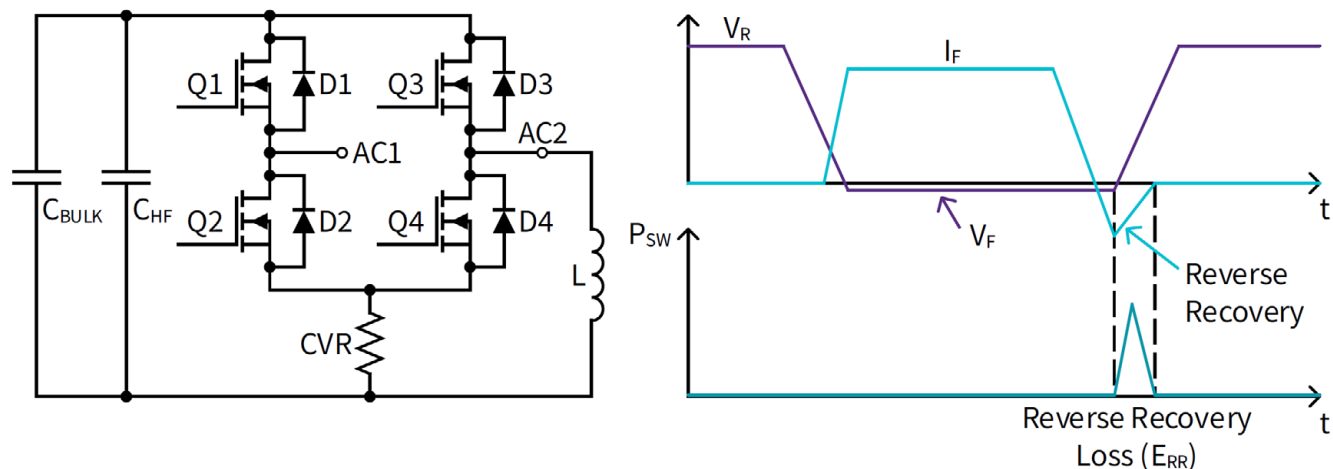

Figure 9: CIL test fixture used to measure the switching loss of body diode D4

3.2.3 Six-Pack

For six-pack power modules, the test fixtures to measure both events are given below in Figure 6 and Figure 7, respectively for the “W” phase leg. Phase legs “U” and “V” are inactive in this example and are configured to remain off during testing to avoid affecting the measurements of the active switch positions. Q5 and Q6 represent the selected switch positions of the Wolfspeed six-pack power module. Likewise, D5 and D6 represent the intrinsic body diodes of each switch position. For both tests, film capacitors (C_{BULK}) are used for bulk energy storage to provide the needed energy transfer to the inductor (L) for the switching event, while high-frequency ceramic capacitors (C_{HF}) are used to provide a low-inductance switching loop. For MOSFET switching measurements in Figure 6, the inductor is connected across the upper switch position of the phase leg from the “W” midpoint to the positive bus rail while Q5 is held off and Q6 is pulsed; for body diode switching measurements in Figure 7, the inductor is connected across the lower switch position of the phase leg to the negative bus rail while Q5 is pulsed and Q6 is held off.

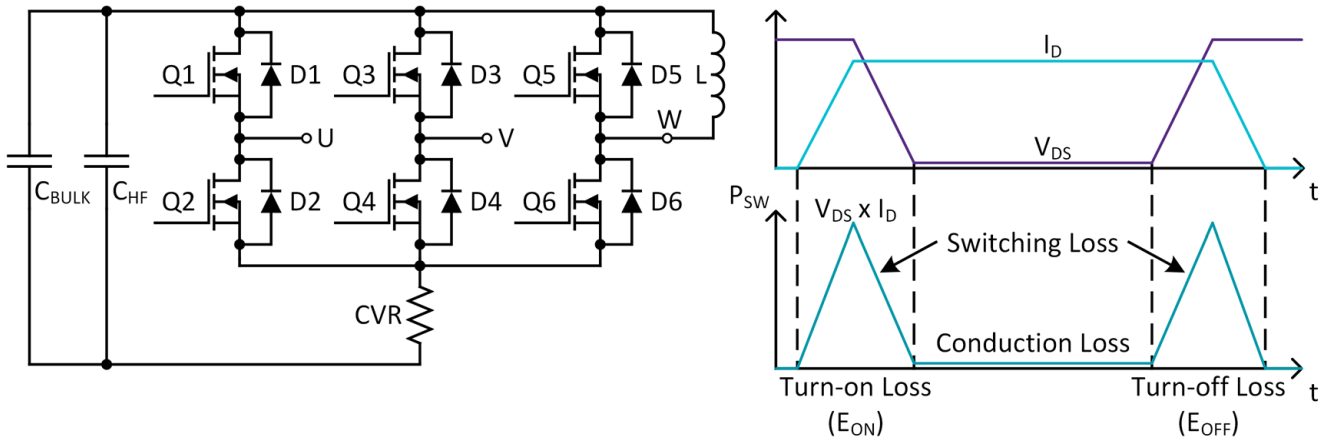

Figure 10: CIL test fixture used to measure the switching loss of MOSFET Q4

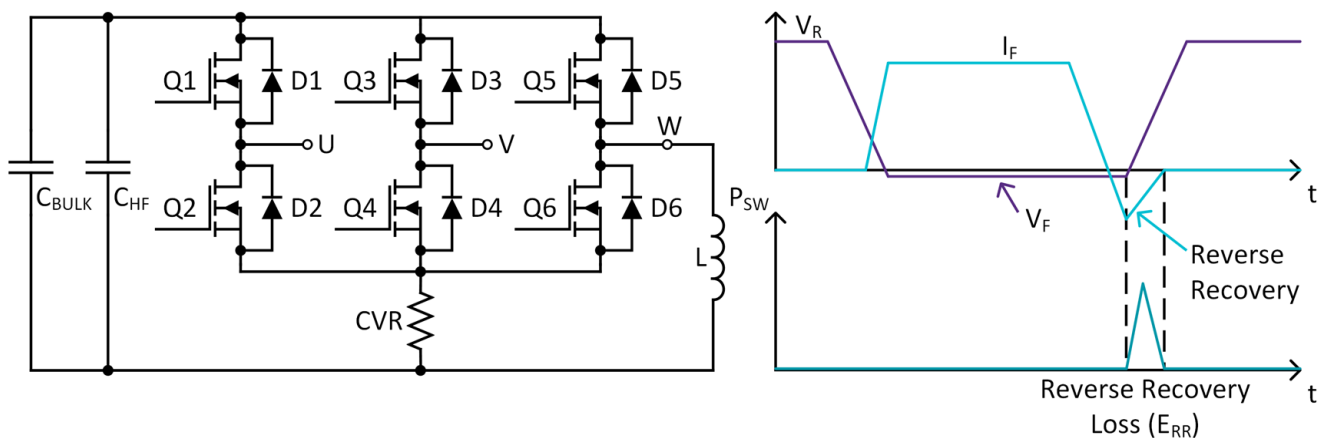

Figure 11: CIL test fixture used to measure the switching loss of body diode Q4

4. Metrology and Peripheral Configuration

The accuracy of time domain measurements (and therefore switching loss calculations) is influenced by the accuracy and bandwidth of the probes used to collect the measurements. This section provides some comparisons of measurement probes and provides recommendations on how to perform accurate current and voltage measurements on Wolfspeed CIL evaluation kits.

In general, ensure that the oscilloscope and probes being used are capable of a bandwidth 3-5x the bandwidth of the signal being measured. As will be shown in the following section, failure to meet this requirement can result in inaccurate measurements.

4.1 Current Sensing Approaches

Two common methods for current measurement in power electronics systems are the current viewing resistor (CVR) and the Rogowski coil. Pictures of a coaxial CVR and Rogowski coil are shown in Figure 12 (a) and Figure 12 (b), respectively. The Rogowski coil is a popular choice since it can easily be added to a circuit and is a non-invasive measurement. However, such probes often have significant bandwidth limitations that make them unsuitable for use with SiC. CVRs, on the other hand, have extremely high bandwidth and can be used to make accurate current measurements. However, they must be placed in series with the transistor, and therefore require careful planning of the PCB layout and will increase the parasitic inductance of the circuit.



Figure 12: Probe examples, (a) current viewing resistor (T & M Research® SSDN-005, 400 MHz), (b) Rogowski current probe (PEM® CWTUM/3/B, 30 MHz)

Figure 13 shows a comparison of the Rogowski coil and CVR for a typical SiC hard switching event. The substantially lower bandwidth of the Rogowski coil leads to an artificial suppression of the ringing present in the experimental waveform. More importantly, it artificially suppresses the initial overshoot and alters the di/dt of the measurement. Additionally, the reduced di/dt predicted at turn-on will also contribute to a lower predicted switching loss. The cumulative effect of the Rogowski coils reduced bandwidth is a decreased estimate of switching losses.

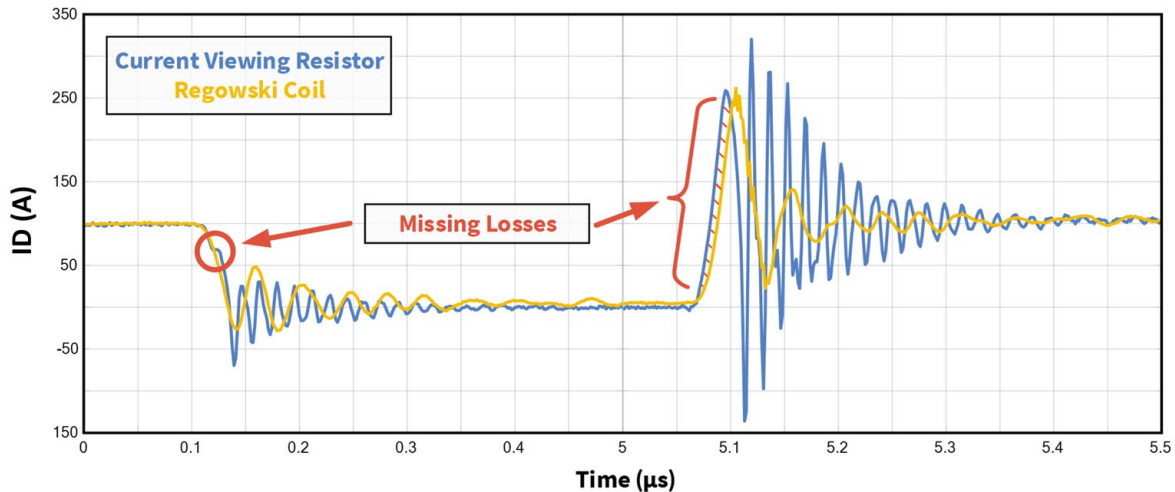

Figure 13: CVR vs Rogowski current probe, CAB011M12FM3 ($T_J = 150^\circ\text{C}$, $R_G = 1\ \Omega$, $V_{DS} = 600\ \text{V}$, $I_D = 100\ \text{A}$)

4.1.1 Current Shunt Types

The general tradeoff in selecting a CVR is between its bandwidth, insertion inductance, and energy rating. For example, smaller shunts with higher resistance often have higher bandwidths, but cannot handle high currents. The recommended shunt for each CIL evaluation kit is described in section 6.

There are two types of current sensors utilized in Wolfspeed CIL evaluation kits, depending on the current rating of the module. The first type of current sensor is the SSDN series tubular type, stud input CVR from T&M Research Products, Inc.[®], shown in Figure 14. The concentric tubular geometry and bolt-on connection allows it to be placed in the high-frequency loop of the power module without introducing excessive parasitic inductance. The resistance values in this package range from 5 m Ω to 100 m Ω , with the energy rating, bandpass frequency, and risetime changing with it (higher resistances will have better performance). For example, the 5 m Ω (SSDN-005) has a bandpass of 400 MHz, a rise time of 1 ns, and a max energy dissipation of 3 J, while the 100 m Ω (SSDN-10) has a bandpass of 2 GHz, a rise time of 0.18 ns, and a max energy dissipation of 2 J.



Figure 14: T&M Research[®] SSDN tubular current shunt

The second current sensor utilized in the CIL evaluation kits is a W Series Bar Strap Type, flat cable input CVR from T&M Research[®] (W-2-0025-4FC), shown in Figure 15. Note that the phenolic insulator has been shortened to be flush with the resistor base. It has a bandpass of 400 MHz and a rise time of 2 ns. The large width and flat bolt-on structure allows it to be placed in the high frequency loop of the power module without introducing

excessive parasitic inductance. In addition, the energy rating of the shunt is 275 J, which allows it to be used for very high current applications.



Figure 15: T&M Research® W-2-0025-4FC 2.5 mΩ CVR

4.1.2 CVR Cabling and Termination

CVRs operate by measuring the voltage drop across the resistor and using the resistance to calculate the current. The voltages measured are very small and are measured using coaxial cables with a BNC termination. Inherently, this is a ground-referenced measurement, and is why the CVR is located on the low-side device. In addition, since the CVR is connected to the grounded oscilloscope, the polarity of the CVR must be addressed by connecting the case side of the CVR to the negative terminal of the module. This establishes a low-impedance ground connection via the CVR's BNC with a coaxial cable connected to the oscilloscope. The channel attenuation can be set to $1/\text{CVR}(\Omega)$ to get the direct current measurement. Furthermore, since the negative terminal of the module has been established as ground, with the case of the CVR connected at this point, the measured current is negative and should be inverted using built-in oscilloscope functions.

Although the CVR provides a high-quality measurement, it is also important to pair this with a high-quality coaxial cable for the BNC connection on the CVR. This is even more important if low-resistance CVRs are utilized, such as the one provided with this kit, as the measurements are more susceptible to noise and errors. For example, for a 2.5 mΩ current shunt, a 200 A current only induces a voltage drop of 0.5 V. Thus, the use of low-loss coaxial cables with high-quality shields and dielectrics is recommended. High-quality cables improve measurement performance by reducing sensitivity to external stray fields. For a direct BNC measurement between the CVR and oscilloscope, a cable of similar performance to the Mini-Circuits® 141-24BM+ is recommended. It features a low loss and excellent return loss with high-frequency coverage. It is long enough to enable measurement without requiring the oscilloscope to be placed extremely close to the test setup and is hand-formable to reduce strain on cabling while still being capable of tight bends.

For even higher-quality measurement, a triple-shielded coaxial cable, such as the Mini-Circuits® CBL-2FT-SMSM+ may be utilized. This cable is not as flexible or convenient but does provide an extremely high-quality measurement. Unfortunately, this family of precision test cables does not have an option for BNC connectors; only SMA connectors are available. Thus, an additional SMA-BNC adapter, such as the Mini-Circuits SF-BM50+, is required on both ends of the cable to interface between the CVR and oscilloscope BNC connectors. Figure 16 shows a comparison between an identical measurement performed with the same CVR; the difference between the two measurements is the coaxial cable connected between the CVR and the oscilloscope. The gold waveform uses a regular coaxial cable, and the purple waveform uses the Mini-Circuits SF-BM50+. The regular coaxial cable shows greater ringing and a measurement anomaly at the beginning of the turn-off event.

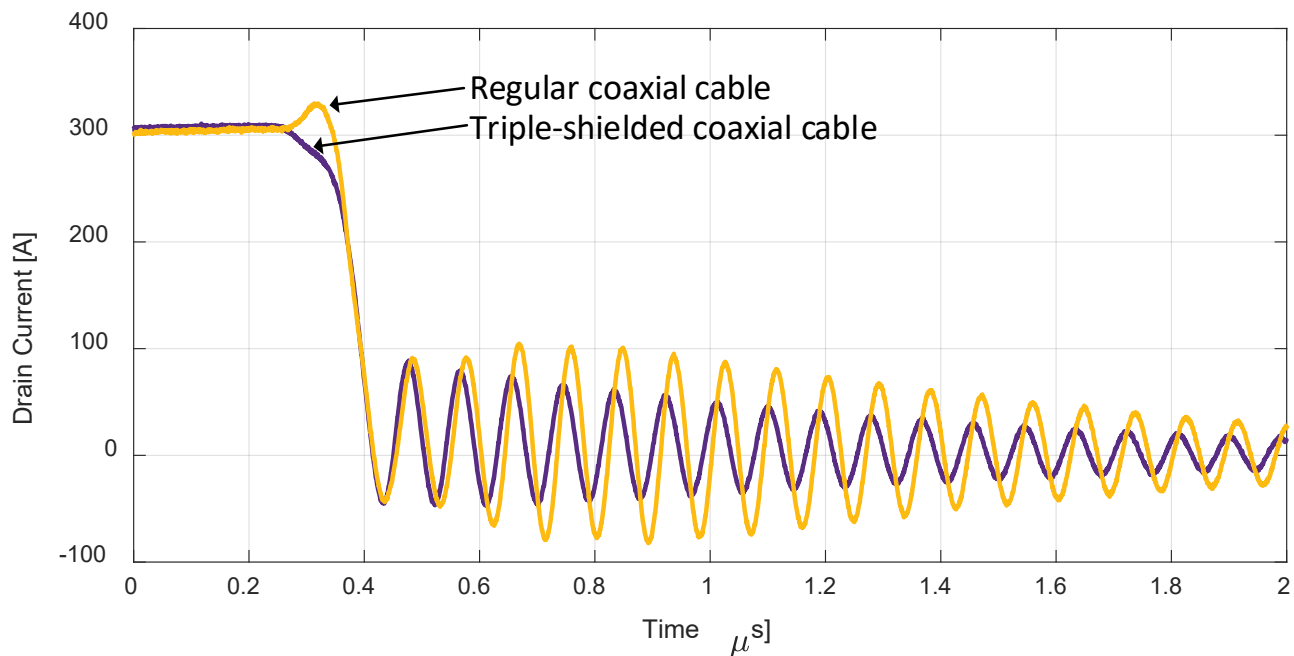

Figure 16: Drain current measurement differences between a low-quality and high-quality coaxial cable

In addition to the coaxial cable, the oscilloscope channel used to measure the CVR’s voltage should also be properly configured. A 50 Ω termination must be present on the oscilloscope for the channel measuring the CVR. This can be accomplished in two ways. The recommended approach is to use an external feed-thru 50 Ω terminator, such as the Tektronix® 011-0049-02, that can be plugged between the coaxial cable and the oscilloscope BNC connector with the oscilloscope termination set to 1 MΩ. This enables a high level of accuracy but provides additional protection for the oscilloscope channel as permissible voltage ranges are typically larger for a 1 MΩ termination. Alternatively, many oscilloscopes have an internal 50 Ω termination setting. This provides high accuracy but adds additional risk to the oscilloscope channel in the case of a failure. Above all, it is imperative that a 50 Ω termination is present. Figure 16 shows a comparison of a coaxial CVR bandwidth with different termination types. Both the external 50 Ω and internal 50 Ω terminations show very similar bandwidth capabilities. However, the gold waveform (1 MΩ termination) shows a significant deviation in accuracy above 10 MHz (0 dB is ideal).

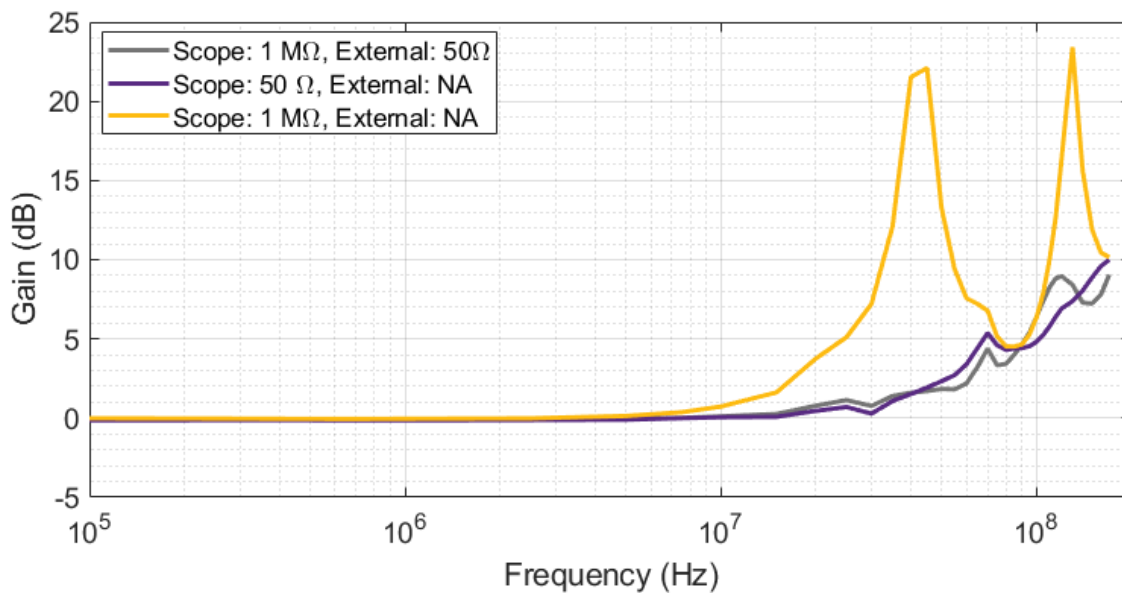

Figure 17: Comparison of CVR bandwidth with different termination types

4.1.3 CVR Installation

The tubular CVR assembly, which can be seen in Figure 18, consists of one T&M Research® SSDN-x, two 3/8-32 nuts, one ¼” flat washer, two #6-32 nuts, and one #6 flat washer. Install two 3/8-32 nuts onto the CVR body and then the ¼” washer. Insert the CVR into the PCB from the top side with the BNC connector facing up. Flip the board over while holding the CVR in place and install the #6 washer followed by the #6 nuts onto the center stud of the CVR. Tighten the nuts on both sides of the board until hand tight and ensure the washers are in contact with the exposed metal contact surface of the PCB. Do not overtighten the nuts. The top-most nut can be tightened against the lower nut to lock it into position and the same can be done with the bottom-most nut. The CVR as installed on the PCB is shown in Figure 18.



Figure 18: Tubular SSDN CVR Installed in PCB from Top View (Left) and Bottom View (Right)

For the bar shunt CVR assembly, which can be seen in Figure 19, the needed assembly hardware (including the 6x32 screws) is provided with the CVR. The bar shunt is mounted on the top side of the PCB, and the two clamping bars are screwed on underneath. Do not overtighten the bolts, as it can damage the threads. Over time, the PCB metallization, clamping bars, and bottom of the bar shunt can become corroded or collect oil and dirt. This can degrade the shunt's performance. Occasional cleaning with a light abrasive and alcohol can remove these imperfections and improve the shunt contact.

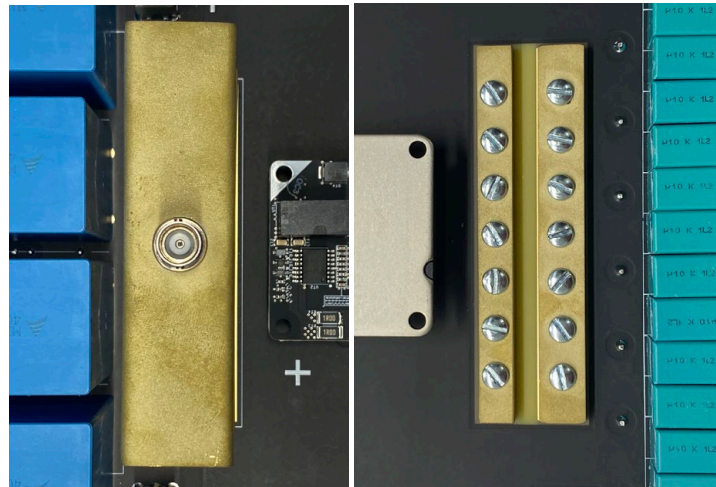

Figure 19: W2 bar CVR Installed in PCB from Top View (Left) and Bottom View (Right)

4.2 Drain-Source Voltage Measurements



Figure 20: (a) Tektronix® differential probe THDP0200 (1500 V Range), (b) Tektronix TPP0850 voltage probe

Two common methods for voltage measurement in power electronics systems are differential probe and the ground-referenced probe. The differential probe is a popular choice since it can be added across arbitrary nodes of the circuit without issue. The ground referenced probe requires caution in implementation as its shield pin is attached to the earth ground of the oscilloscope. Incorrect implementation of a ground reference measurement will generally lead to small ground currents on the probe reference which substantially reduce the accuracy of the measurement. In more serious cases (where the ground reference shield is connected to a power signal), large currents can flow through earth ground destroying the probe or oscilloscope. In the worst case, a failed connection from the instrument to the earth ground can cause the outer metal casing of the oscilloscope to float to the bus potential and pose a serious threat to operator safety.

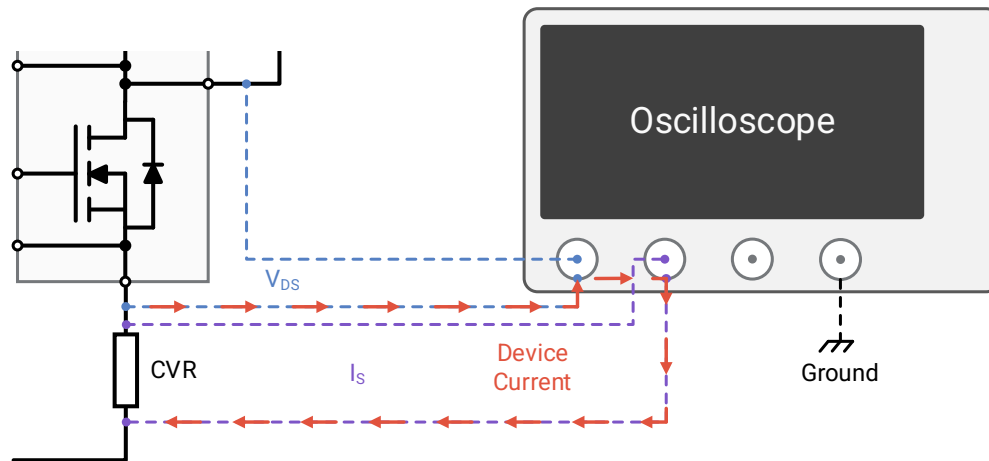

Figure 21: Potential grounding error when using CVR and ground reference probe

The grounding issue becomes more critical when also using a ground-referenced CVR. As shown by Figure 21, when using a ground referenced probe in combination with a CVR, it is possible to bypass the CVR via the scope shielding path. This can cause the entire device current to flow through the oscilloscope, which is likely to destroy the voltage probe or oscilloscope. It also presents a substantial safety hazard. In general, differential probes are recommended for measurements of device drain to source, and it is recommended to only use a single ground-referenced probe in a system.

4.3 Gate-Source Voltage Measurements



Figure 22: Probe examples, (a) Tektronix® differential probe THDP0200 (150 V Range), (b) Tektronix® IsoVu TIVH05 (TIVPMX10X, ±25 V sensor tip)

Measuring the gate-source voltage of a power module comes with an additional challenge in that it is a small-signal measurement in the presence of significant electromagnetic interference (noise) during switching events. In addition, the gate nodes (especially on the high side) can be floating at hundreds of volts, and therefore isolated differential measurements must be used. This requires a measurement device that is both decoupled from ground and that features a very high common mode rejection ratio. The traditional metrology for this high-side gate voltage measurement is a standard differential probe, but newer, optically isolated probes can make this measurement more accurately.

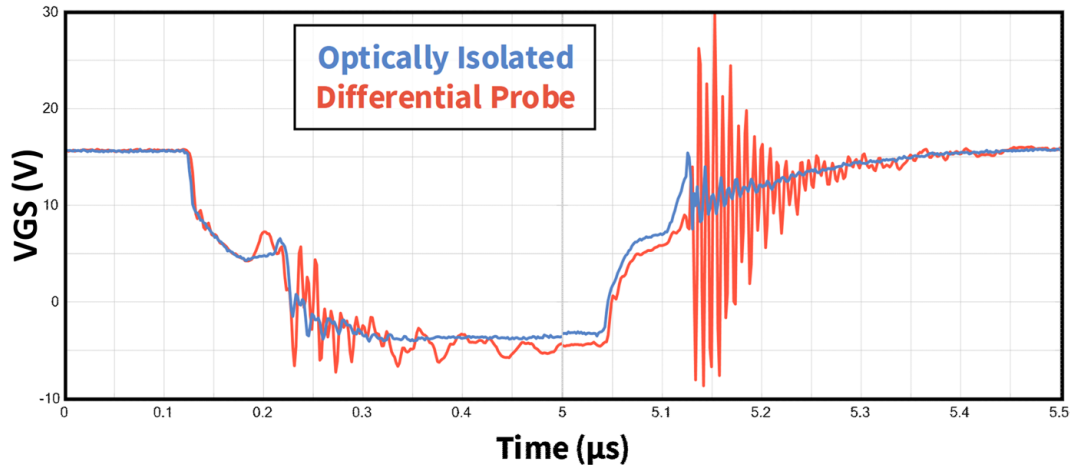

Figure 23: Differential probe vs optically isolated probe, CAB016M12FM3 ($T_J = 150^\circ\text{C}$, $V_{DS} = 800\text{ V}$, $I_D = 200\text{ A}$)

Figure 23 shows a comparison of the high-side gate voltage for the standard differential probe versus the optically isolated probe. Both at turn-off and turn-on, high-frequency ringing can be seen on the gate after the device’s gate passes through the threshold region. Due to coupling between the gate and power loop, some ringing is expected. However, in the case of the differential probe, the ringing has a significantly higher amplitude than is measured by the optically isolated probe. This is likely due to the changing reference voltage inducing common mode currents within the probe and is an artifact of the standard differential probe. While the waveform measured by the differential probe in Figure 23 appears to pass the maximum gate voltage of the device, the more accurate measurement of the optically isolated probe makes it clear that the device is within specification. Application designers using standard differential probes for gate voltage measurements should use caution as it may not be possible to differentiate between the measurement artifact shown here and an actual violation of the device ratings.

4.4 Probe Delay Compensation (Deskew)

All measurements have a delay between when the signal occurs and when it is recorded into the oscilloscope’s buffer. For passive probes, such as CVR measurements using a BNC cable, this delay is caused by the time it takes the signal to propagate through the cable and is usually on the order of 5 ns – 20 ns. For active probes, delay caused by additional processing (especially for optically isolated probes) can add additional delay up to 50+ ns (note: manufacturers will often provide or automatically program a compensation of this delay for active probes). Because the delay for each measurement can be different, it is generally the case that the signals displayed on the oscilloscope will have time offsets between them. This can cause issues when analyzing CIL measurements to quantify delay times and switching losses.

For example, consider the CIL waveforms in Figure 24. The top two plots show the voltage (V_{DS}) and current waveforms (I_D) at the turn-off and turn-on events. The drain current is shifted in time from -25 ns to 25 ns in 5 ns increments. The bottom waveforms are the calculated instantaneous power from the voltage and current waveforms ($V_{DS} \cdot I_D$). As the drain current is shifted rightward, the turn-off power waveform increases in magnitude, while the turn on power waveform decreases in magnitude. The relative shift in time from one waveform to another is referred to as deskew.

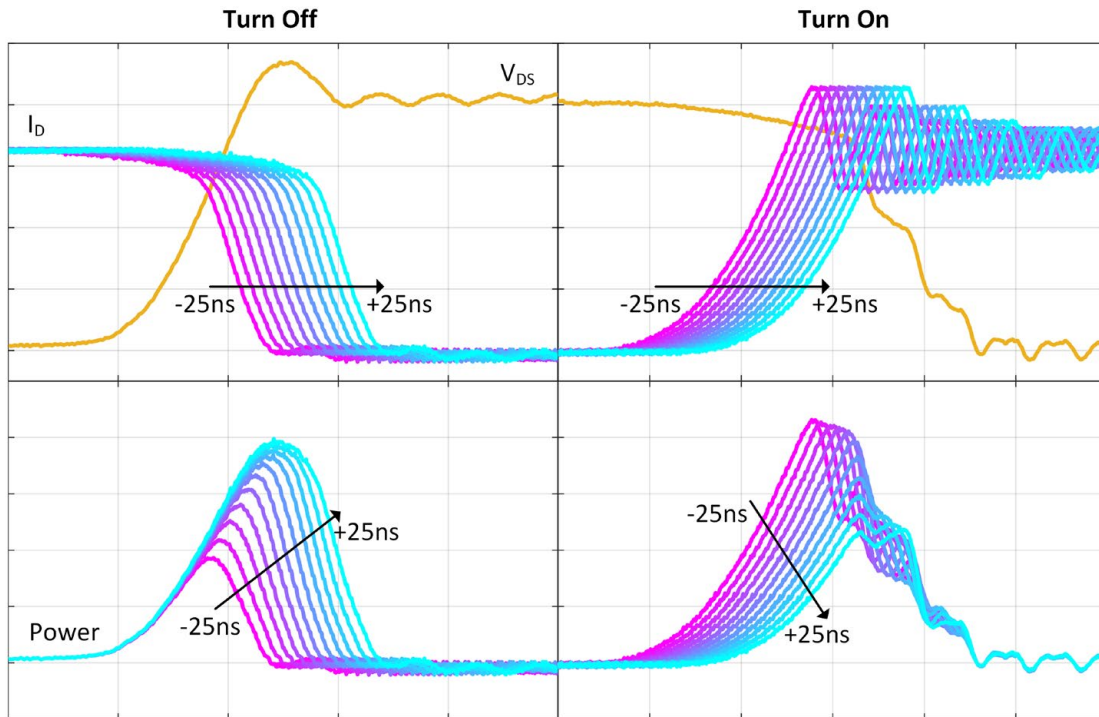

Figure 24: Affect of deskew on turn off and turn on power waveforms

The switching power waveforms in Figure 24 were integrated to obtain the switching energy at each deskew value for the turn-off and turn-on events, and in addition were summed to obtain the total losses. The resulting energies across deskew are plotted in Figure 25. While the turn off and turn on losses are heavily dependent on the deskew, the total losses are nearly constant. Thus, when analyzing data, it's important to understand that the portion of losses attributed to the turn-off and turn-on events are highly sensitive to the deskew. For applications where it is important to consider this distinction, the deskew of your system should be quantified carefully.

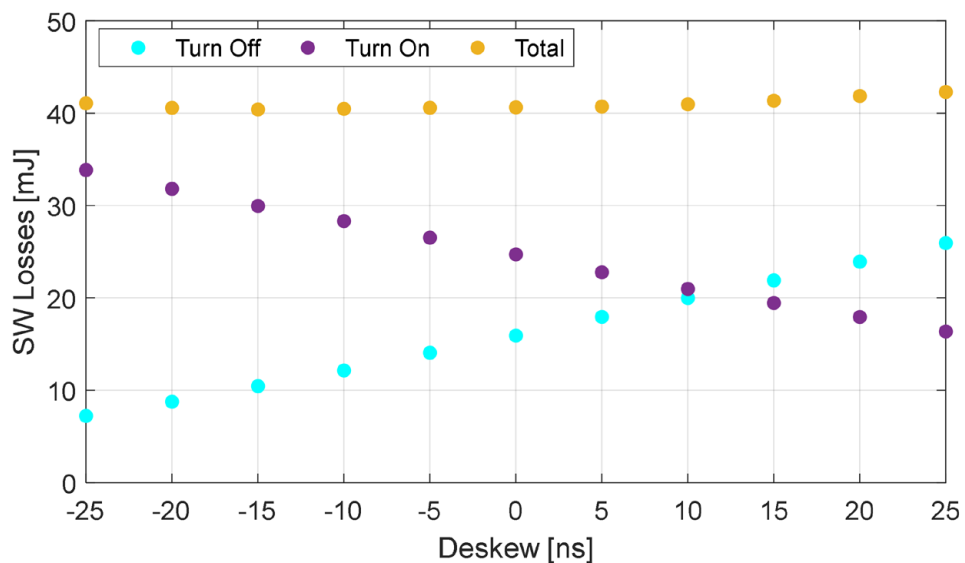

Figure 25: Switching energy across deskew timings

Probe delay can be compensated inside the oscilloscope settings for each channel. One approach to quantify the delay is to design a PCB that allows multiple probes to be simultaneously connected to a high-frequency input stimulus. The compensation delay can then be adjusted for each channel until they are aligned. An example PCB designed for this purpose is shown in Figure 26. The stimulus signal is injected into the center BNC connector, generally from an arbitrary waveform generator. Various other connectors are spread around the edge of the PCB and are all equidistant from the center stimulus (this is necessary such that the propagation delay of the signal through the PCB to each connector are the same). It is recommended to use a square wave signal with an edge rate similar to the edge rates of the SiC MOSFETs when switched because the delay response of probes can be dependent on frequency. Generally, a signal on the order of 1-10 V/ns is sufficient.

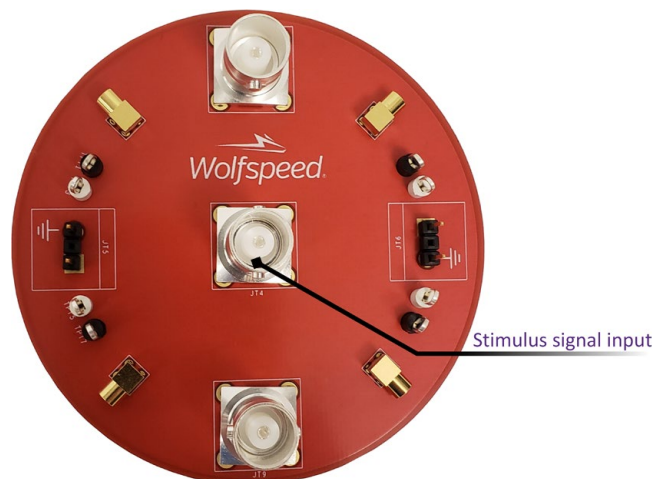

Figure 26: Deskew compensation PCB

4.5 Gate Signal Sequencing

Wolfspeed gate drivers accept differential PWM logic inputs to control their output to the MOSFET. The exact specifications of this input may vary depending on the gate driver and can be found in its respective datasheet. It is recommended to interface with Wolfspeed gate drivers with the [CGD12HB00D](#) differential transceiver board. The CGD12HB00D can convert single-ended inputs (such as from a waveform generator) into differential outputs compatible with Wolfspeed gate drivers. It also is compatible with several gate drive safety protection features. More information on its use can be found in the CGD12HB00D datasheet.



Figure 27: CGD12HB00D differential transceiver

4.6 Temperature Setting

To facilitate dynamic characterization of the power module at operating temperatures above room temperature, a hot plate can be used in conjunction with the dynamic evaluation board to heat the power module to the desired temperature. The complete evaluation board can be positioned over the hot plate with only the bottom of the power module in contact with the hot plate surface. If present, the temperature sensor in the module can be used to verify that the devices have reached the correct temperature. To ensure the maximum junction temperature is not exceeded, slowly ramp up the temperature to the final setpoint to avoid temperature overshoot and monitor the temperature of the module with the temperature sensor. Exercise care when using a hot plate as the module, PCB, and other components may be hot.



Figure 28: FM3 Module on Hot Plate for Elevated Temperature Testing

5. Charging and Discharging Sequence

Operating Wolfspeed CIL evaluation kits requires charging the bulk capacitors to the operating voltage of the device. Due to the high voltages and high switching speeds involved, it is important to carefully develop a charging and discharging sequence that can be done remotely from the system. Because it is only necessary to charge the bulk capacitors, using a power supply with a low current rating is adequate and can save on cost. The suggested high-voltage power supply for Wolfspeed CIL evaluation kits is a 2 kV, 150 mA, non-isolated supply from Glassman High Voltage® (PS/FR2P150). This provides a low-cost solution that inherently does not have a large amount of energy storage. A picture of the Glassman power supply is shown in Figure 29.



Figure 29: Glassman High Voltage® PS/FR2P150 non-isolated power supply

Because the power supply is non-isolated, high-voltage relays are needed to open the ground loops formed due to the measurement circuitry and to charge/discharge the bulk energy storage. If ground loops are not properly removed, the resulting measurements will be significantly impacted. For safety, normally closed relays should be used in case of a loss of control power. Furthermore, a large bleed-off resistance is connected directly across the bulk capacitors on the evaluation board PCB to slowly discharge the energy storage to a safe level. Three relays are used to create the three operating states required to complete a CIL test: CHARGE, TEST and DISCHARGE. Each operating state is further explained below. The CIL test fixture schematic with the addition of the high-voltage power supply and high voltage relays is given for each respective operating state in Figure 30, Figure 31, and Figure 32.

Note that the test fixture schematic shown is for MOSFET switching analysis, but it is also applicable to body diode switching analysis where the inductor is connected across Q2.

CHARGE: Relay 1 and Relay 3 are CLOSED to enable charging of the bus bulk capacitors. A ground loop is formed via the non-isolated power supply return and ground reference established by the oscilloscope. Once the bus is charged, the transition to the TEST state can be made. See Figure 30.

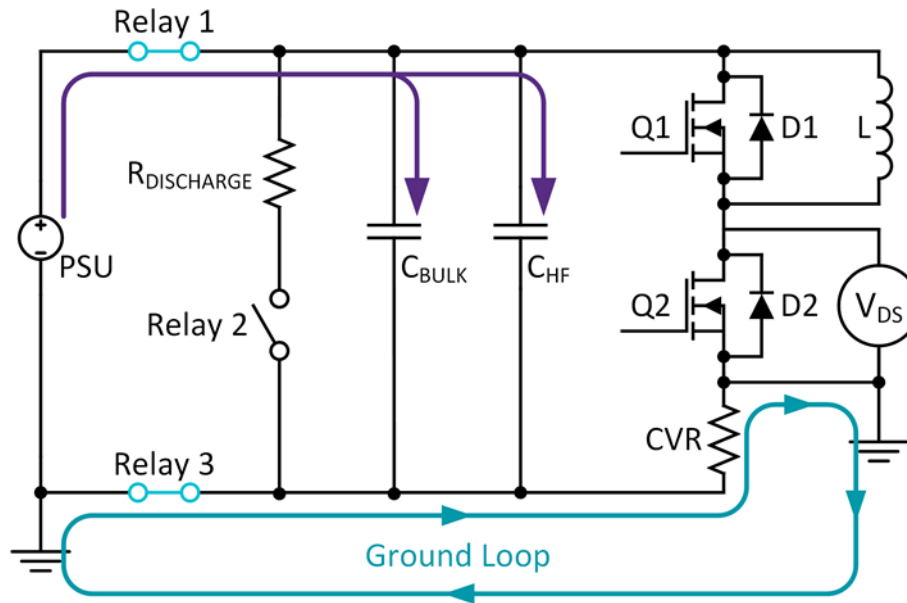

Figure 30: CIL Test Fixture Schematic During the CHARGE State

TEST: All relays are OPEN, removing the ground loop and referencing the test circuit to the established ground connection made via the oscilloscope. The CIL test can then be performed. Once the test is complete, the transition to the DISCHARGE state can be made, or the transition to the CHARGE state can be made to perform additional testing without discharging the bus capacitors. See Figure 31.

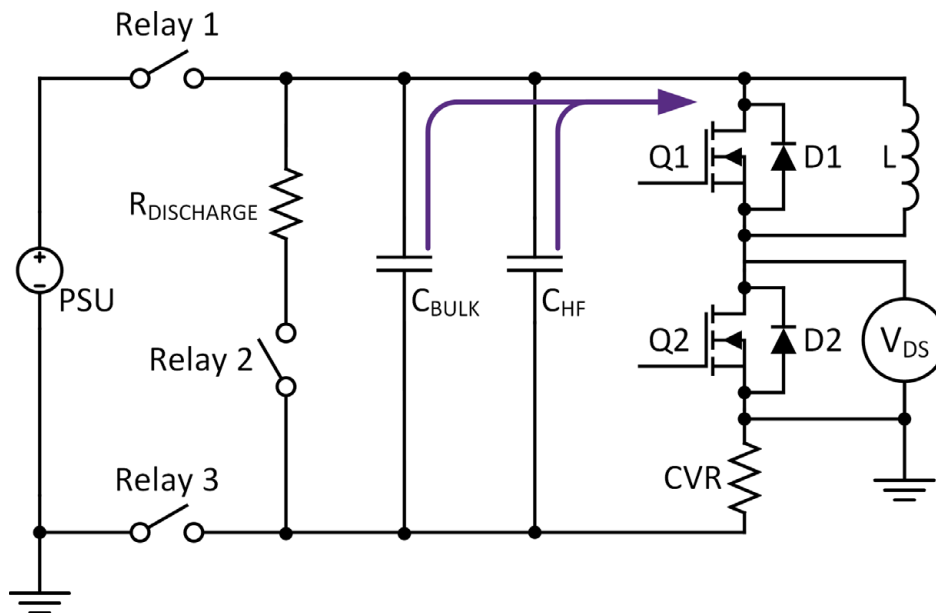

Figure 31: CIL Test Fixture Schematic During the TEST State

DISCHARGE: In the final state, all relays are CLOSED to discharge the dc bus bulk capacitors and output capacitance of the high voltage power supply via the Discharge Resistor. Proper sizing of the Discharge Resistor should be considered in terms of power dissipation and the time required to discharge. See Figure 32.

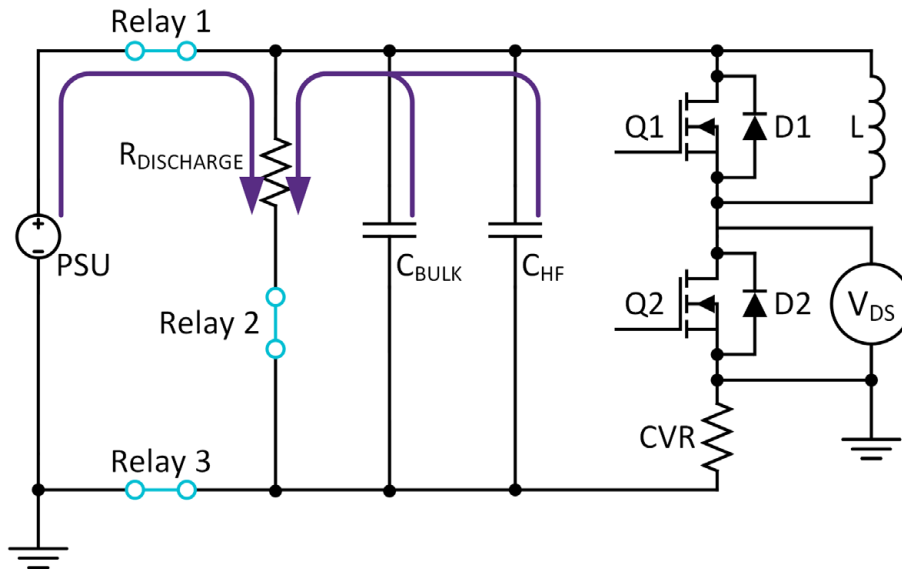

Figure 32: CIL test Fixture Schematic During the DISCHARGE State

6. Wolfspeed Evaluation Kits Hardware Overview

A general overview of the available Wolfspeed CIL evaluation kits is provided herein. Not all evaluation kits may be described in this section, but the general layout is similar between products. In addition, the information here is not comprehensive; additional information including the schematics, BOM, layout, and PCB fabrication instructions can be found on each product page on Wolfspeed’s website.

A general gate drive option is provided for each evaluation kit. However, the gate driver utilized to control the module for dynamic evaluation should match the characteristics of the gate driver that will ultimately be utilized in the final system. In addition, there may be multiple gate driver options for a module available on Wolfspeed’s website.

Please refer to the respective module’s mounting user guide, which can be found under [Wolfspeed’s document library](#) for information on properly mounting each module to its CIL evaluation kit PCB.

For several 1.2 kV products, two bulk capacitor configurations are provided. The default configuration uses a single 200 μF , 1.1 kV film capacitor, part B32778J0207K000 from TDK Electronics® (formerly EPCOS). However, if this component is out of stock or otherwise unavailable, four 40 μF , 1.1 kV film capacitors, part B32778G0406K000 from EPCOS/TKD, can be used instead. This configuration is shown in the schematic for the applicable parts, shown in Figure 33.

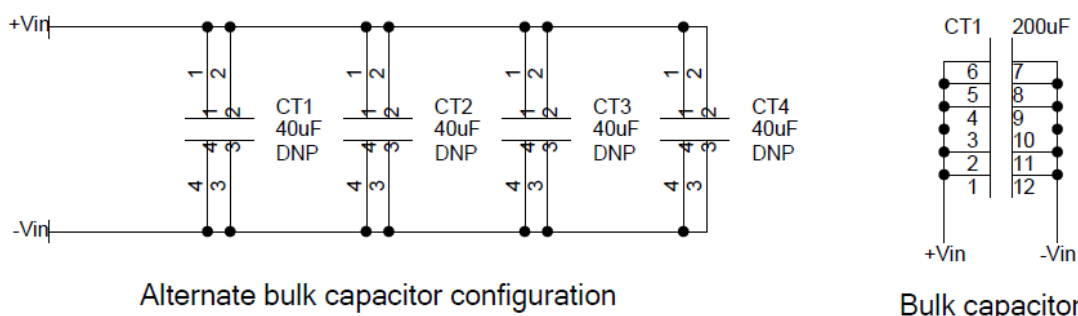

Figure 33: Bulk capacitor schematic configurations

6.1 KIT-CRD-CIL12N-XM3

The KIT-CRD-CIL12N-XM3 evaluation board, shown in Figure 34, can be used to characterize 1.2 kV Wolfspeed XM3 power modules. The configuration in Figure 34 shows a mounted XM3 power module and its recommended CGD12HBXMP gate driver (these are not included with the evaluation kit). The PCB contains a 1.1 kV 200 μ F bulk capacitor, thirty parallel 1 kV 0.1 μ F high-frequency capacitors, a 2.5 m Ω bar shunt CVR, and screw terminals for attaching the load inductor. For switching measurements, attach the load inductor to the ‘+’ and ‘MID’ screw terminals, and switch the low-side MOSFET. For reverse recovery measurements, attach the load inductor to the ‘-’ and ‘MID’ screw terminals and switch the high-side MOSFET. Here, the ‘+’ and ‘-’ labels refer to the screw terminals located on both sides of the PCB. A BNC connector is available for drain-source voltage measurements of the low-side, but it is recommended to use a differential voltage probe on the adjacent pins for more accurate measurements. The input leads from the high-voltage power supply should be connected to the ‘+’ and ‘-’ terminals located behind the bulk capacitor.

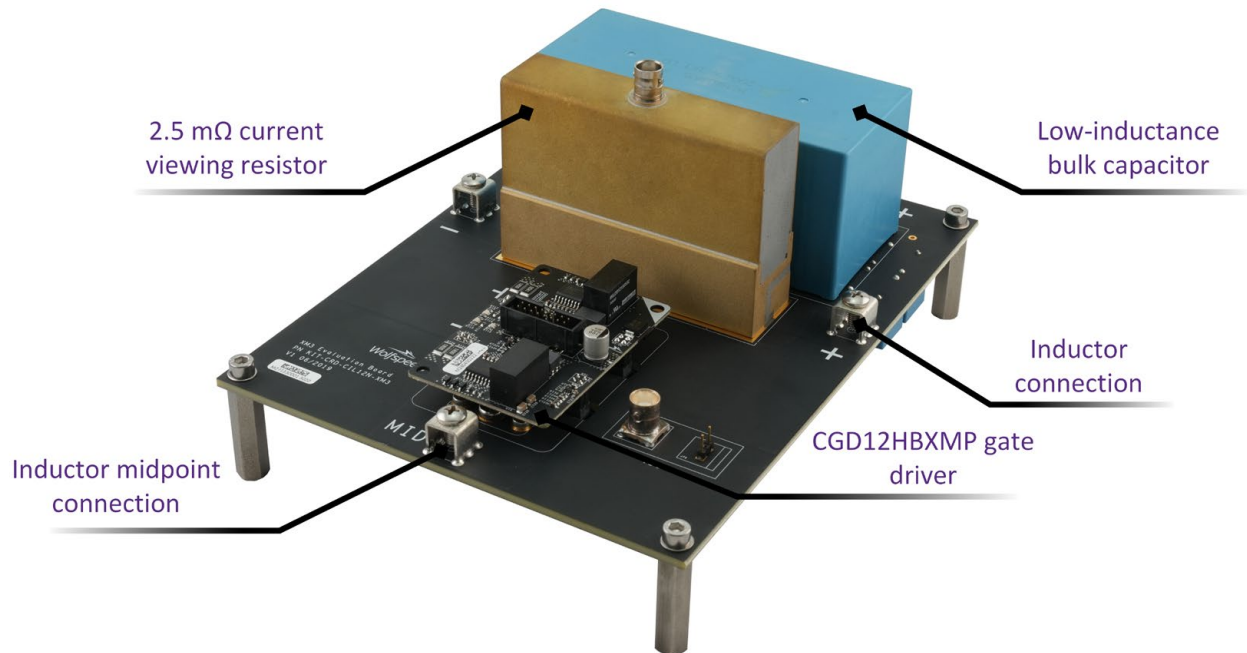

Figure 34: KIT-CRD-CIL12N-XM3 evaluation board

6.2 KIT-CRD-CIL17N-XM

The KIT-CRD-CIL17N-XM evaluation board, shown in Figure 35, can be used to characterize 1.7 kV Wolfspeed XM power modules. The configuration in Figure 35 shows a mounted XM power module and its recommended CGD1700HB2P-XM3 gate driver (these are not included with the evaluation kit). The PCB contains five parallel 1.5 kV 22 μ F bulk capacitors, thirty parallel 1.5 kV 0.047 μ F high-frequency capacitors, a 2.5 m Ω bar shunt CVR, and screw terminals for attaching the load inductor. For switching measurements, attach the load inductor to the ‘+’ and ‘MID’ screw terminals, and switch the low-side MOSFET. For reverse recovery measurements, attach the load inductor to the ‘-’ and ‘MID’ screw terminals and switch the high-side MOSFET. Here, the ‘+’ and ‘-’ labels refer to the screw terminals located on both sides of the PCB. Drain-source voltage measurements on the high and low side can be measured using the test points located on the PCB. The input leads from the high-voltage power supply should be connected to the ‘+’ and ‘-’ terminals located behind the bulk capacitors.

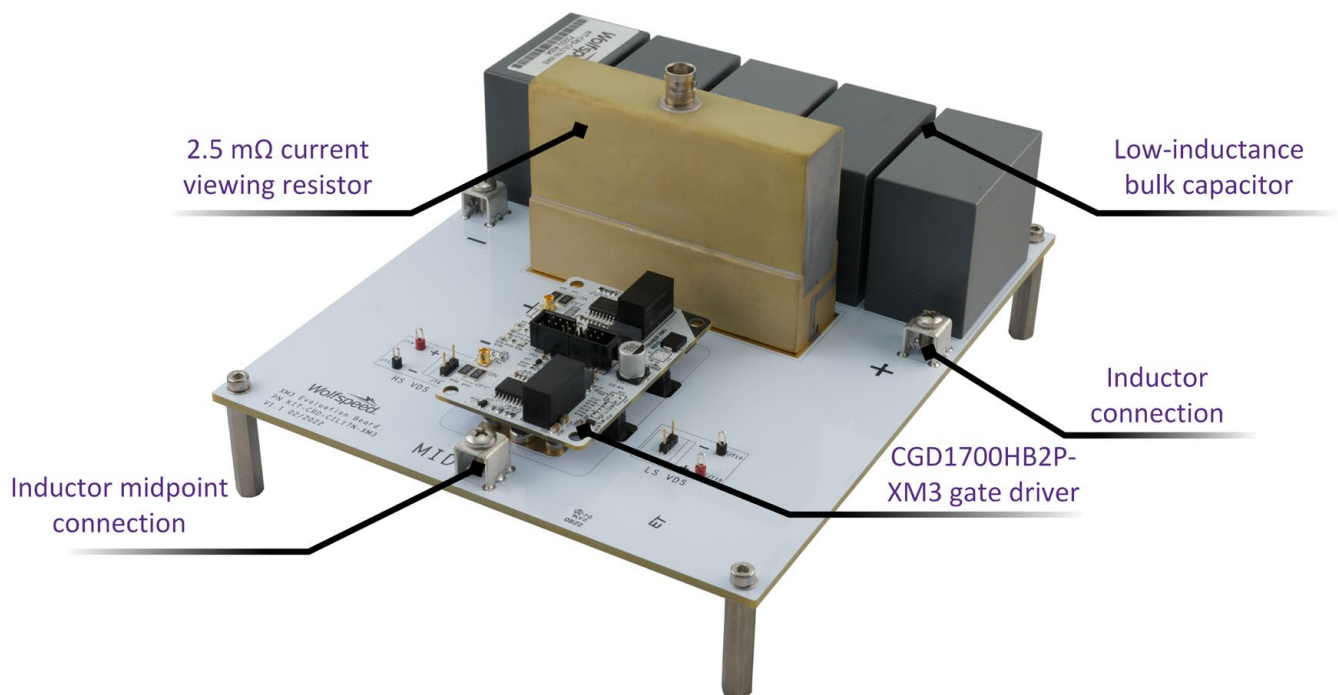

Figure 35: KIT-CRD-CIL17N-XM evaluation board

6.3 KIT-CRD-CIL12N-BM

The KIT-CRD-CIL12N-BM evaluation board, shown in Figure 36, can be used to characterize 1.2 kV Wolfspeed BM modules. The configuration in Figure 36 shows a mounted XM3 power module and its recommended CGD1200HB2P-BM gate driver (these are not included with the evaluation kit). The PCB contains a 1.1 kV 200 μ F bulk capacitor, thirty parallel 1 kV 0.1 μ F high-frequency capacitors, a 2.5 m Ω bar shunt CVR, and screw terminals for attaching the load inductor. For switching measurements, attach the load inductor to the ‘+’ and ‘MID’ screw terminals, and switch the low-side MOSFET. For reverse recovery measurements, attach the load inductor to the ‘-’ and ‘MID’ screw terminals and switch the high-side MOSFET. Here, the ‘+’ and ‘-’ labels refer to the screw terminals located on both sides of the PCB. A BNC connector is available for drain-source voltage measurements of the low-side, but it is recommended to use a differential voltage probe on the adjacent pins for more accurate measurements. The input leads from the high-voltage power supply should be connected to the ‘+’ and ‘-’ terminals located behind the bulk capacitor.

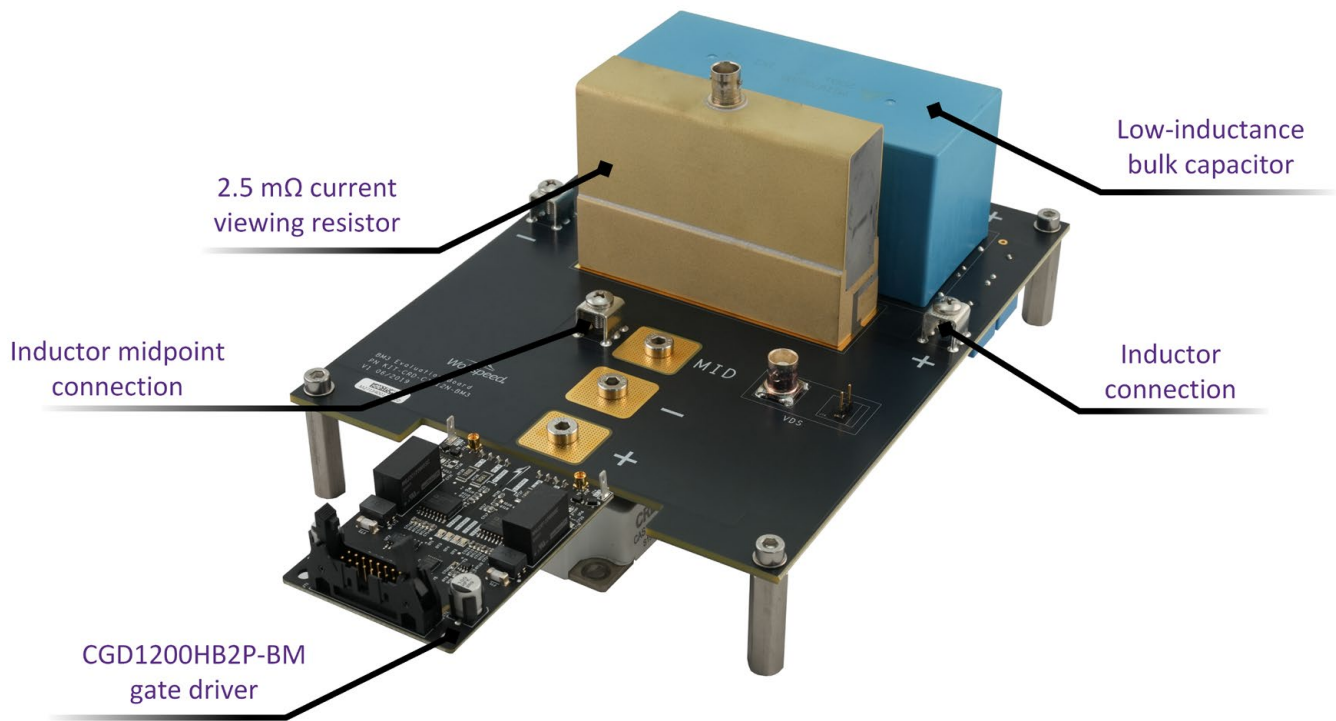

Figure 36: KIT-CRD-CIL12N-BM evaluation board

6.4 KIT-CRD-CIL17N-BM

The KIT-CRD-CIL17N-BM evaluation board, shown in Figure 37, can be used to characterize 1.7 kV Wolfspeed BM power modules. The configuration in Figure 37 shows a mounted XM3 power module and its recommended CGD1700HB2P-BM gate driver (these are not included with the evaluation kit). The PCB contains five parallel 1.5 kV 22 μ F bulk capacitors, thirty parallel 1.5 kV 0.047 μ F high-frequency capacitors, a 2.5 m Ω bar shunt CVR, and screw terminals for attaching the load inductor. For switching measurements, attach the load inductor to the '+' and 'MID' screw terminals, and switch the low-side MOSFET. For reverse recovery measurements, attach the load inductor to the '-' and 'MID' screw terminals and switch the high-side MOSFET. Here, the '+' and '-' labels refer to the screw terminals located on both sides of the PCB. Drain-source voltage measurements on the high and low side can be measured using the test points located on the PCB. The input leads from the high-voltage power supply should be connected to the '+' and '-' terminals located behind the bulk capacitors.

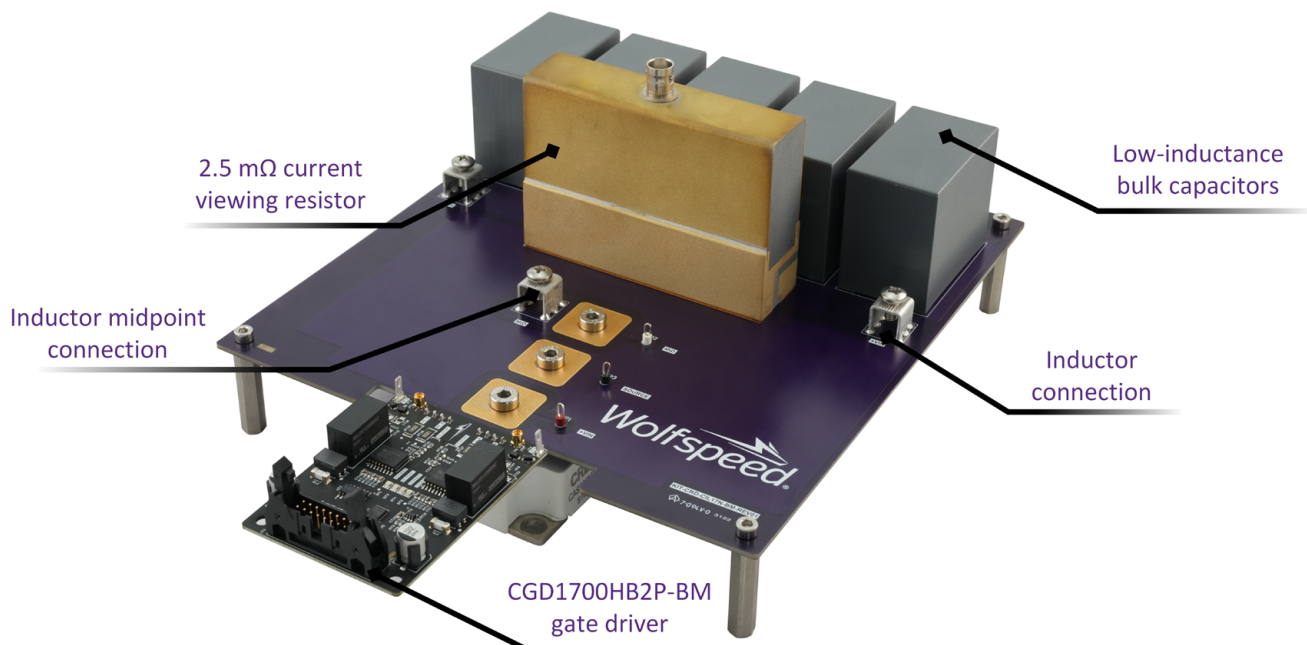

Figure 37: KIT-CRD-CIL17N-BM evaluation kit

6.5 KIT-CRD-CIL17N-HM3

The KIT-CRD-CIL17N-HM3 evaluation board, shown in Figure 38, can be used to characterize 1.2 kV Wolfspeed HM3 power modules. The PCB contains five parallel 1.5 kV 22 μ F bulk capacitors, thirty parallel 1.5 kV 0.047 μ F high-frequency capacitors, a 2.5 m Ω bar shunt CVR, and screw terminals for attaching the load inductor. For switching measurements, attach the load inductor to the '+' and 'MID' screw terminals, and switch the low-side MOSFET. For reverse recovery measurements, attach the load inductor to the '-' and 'MID' screw terminals and switch the high-side MOSFET. Here, the '+' and '-' labels refer to the screw terminals located on both sides of the PCB. Drain-source voltage measurements on the high and low side can be measured using the test points located on the PCB. The input leads from the high-voltage power supply should be connected to the '+' and '-' terminals located behind the bulk capacitors.

Note: Please refer to the online design files for more information on the KIT-CRD-CIL12N-HM3 CIL evaluation kit.

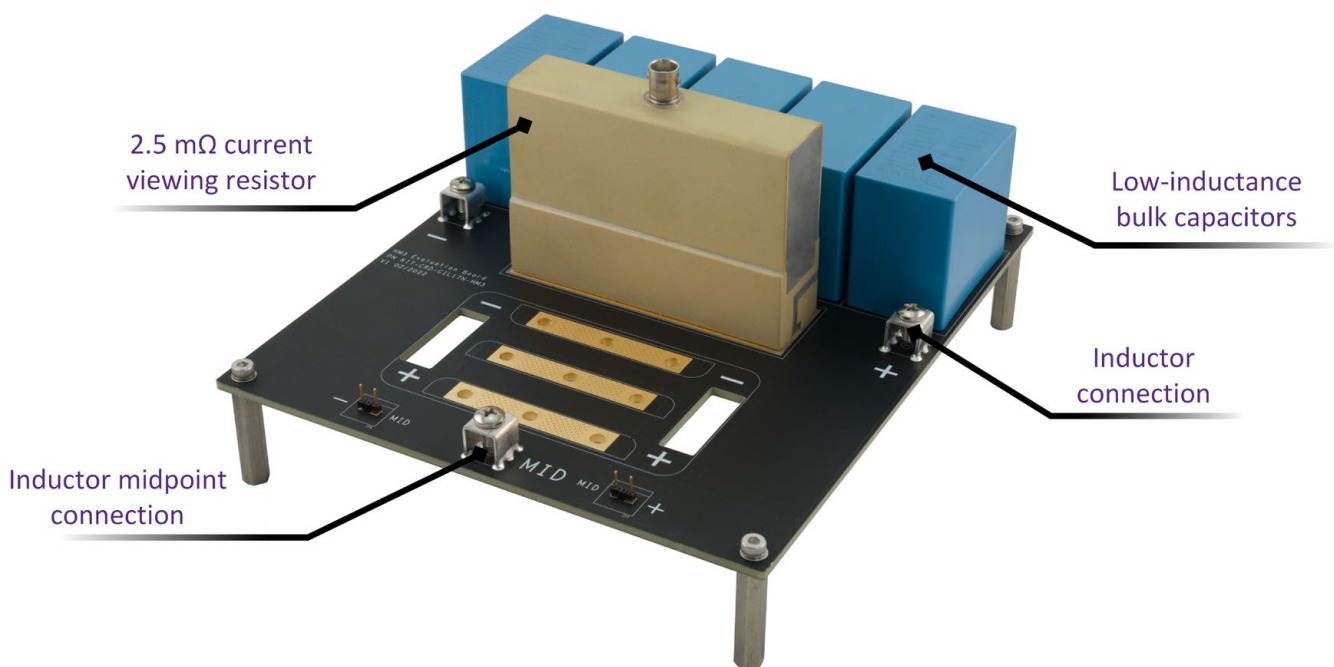

Figure 38: KIT-CRD-CIL17N-HM3 Evaluation Board

6.6 Press-Fit Module Notes

For the press-fit modules described in the following sections (FMA, FMB, FMC, GMA, and DMA), additional pins are available on the respective CIL evaluation kit PCB for gate drive mounting, DESAT connections, measurements, and temperature sensing.

6.6.1 Gate Driver Mounting

Because the press-fit module pins are pressed into the PCB, the gate driver does not mount on the module directly. Instead, headers are present on the PCB itself that can be used to mount the gate driver. Figure 39 shows an example of the installation location for the gate driver board with the pair of 4-pin headers corresponding to the high-side and low-side gate driver channels.

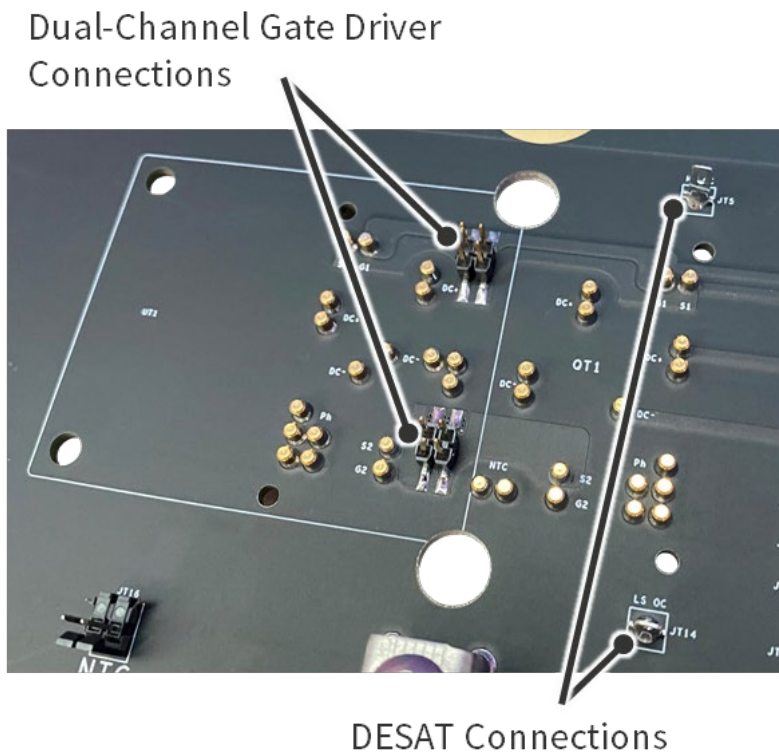

Figure 39. Dual-Channel isolated gate drive interface

6.6.2 Gate-Source Measurements

Test points are included on the evaluation board to facilitate measuring the gate-source voltage for all switch positions. Standard test points for the gate and source terminals of all switch positions can be used with high-bandwidth, isolated differential voltage probes. An MMCX connector is also provided for a high-frequency, low-noise measurement with suitable probes such as the Tektronix® TIVP1.

6.6.3 NTC Temperature Sensing

For power modules that include a built-in NTC temperature sensor, the terminals are exposed via a standard 2.54 mm 2-pin header. If the gate driver board includes a temperature sensor feedback input, this header can be used with a short cable to connect the input to the module's built-in sensor. This header can be used with external equipment such as a digital multimeter to measure the resistance of the NTC.

6.6.4 DESAT Terminal

Terminals are provided on the evaluation board to facilitate the connection of the Kelvin Drain to the DESAT or Over-current pin of the gate driver. One terminal is tied to V+ for the drain-kelvin of Q1 and should be connected to the high-side gate driver drain pin. The second terminal is tied to the midpoint for the drain-kelvin of Q2 and should be connected to the low-side gate driver drain pin. The connectors use 0.110" tab quick-connect terminals and a suitable mating connector and jumper wire should be used to make the connection to the gate driver board. Both DESAT cables should always be installed as the gate driver output will not turn on without this connection.

6.7 KIT-CRD-CIL12N-FMA

The KIT-CRD-CIL12N-FMA evaluation board, shown in Figure 40, can be used to characterize 1.2 kV Wolfspeed half-bridge FM power modules. The configuration in Figure 40 shows a mounted FM power module and its recommended CGD1700HB2P-UNA gate driver (these are not included with the evaluation kit). The configuration shown in Figure 40 uses four parallel 1.1 kV 40 μ F bulk capacitors, thirty parallel 1.5 kV 0.047 μ F high-frequency capacitors, a 5 m Ω tubular CVR, and screw terminals for attaching the load inductor. For switching measurements, attach the load inductor to the '+' and 'MID' screw terminals, and switch the low-side MOSFET. For reverse recovery measurements, attach the load inductor to the '-' and 'MID' screw terminals and switch the high-side MOSFET. Here, the '+' and '-' labels refer to the screw terminals located behind the bulk capacitor (there are two + and two - terminals that may be used interchangeably). Drain-source voltage measurements on the high and low side can be measured using the test points located on the PCB. Gate-source voltage measurements can be measured on the gate driver or by the 'HS VGS' and 'LS VGS' regions on the PCB. The input leads from the high-voltage power supply should be connected to the '+' and '-' terminals located behind the bulk capacitors.

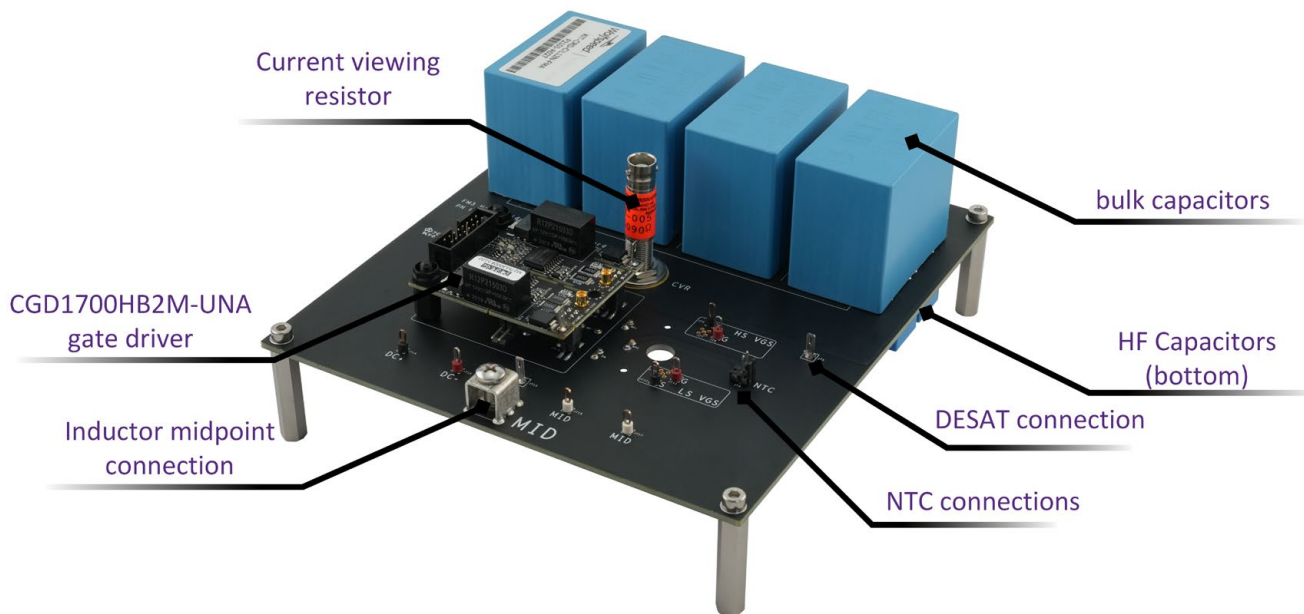

Figure 40: KIT-CRD-CIL12N-FMA CIL evaluation kit

6.8 KIT-CRD-CIL12N-FMB

The KIT-CRD-CIL12N-FMB evaluation board, shown in Figure 41, can be used to characterize 1.2 kV Wolfspeed full-bridge FM power modules. The recommended gate driver is the CGD1700HB2P-UNA. The picture in Figure 41 shows the configuration using four parallel 1.1 kV 40 μF bulk capacitors and thirty parallel 1.5 kV 0.047 μF high-frequency capacitors, a 5 m Ω tubular shunt CVR, and screw terminals for attaching the load inductor. For switching measurements, attach the load inductor to the ‘+’ and ‘AC1’ (or ‘AC2’, depending on the phase being tested) screw terminals, and switch the low-side MOSFET. For reverse recovery measurements, attach the load inductor to the ‘-’ and ‘AC1’ (or ‘AC2’, depending on the phase being tested) screw terminals and switch the high-side MOSFET. Here, the ‘+’ and ‘-’ labels refer to the screw terminals located behind the bulk capacitors (there are two + and two - terminals that may be used interchangeably). Gate driver connections are broken out for each phase leg of the full-bridge module and jumpers are used to keep unused switch positions off. The input leads from the high-voltage power supply should be connected to the ‘+’ and ‘-’ terminals located behind the bulk capacitors.

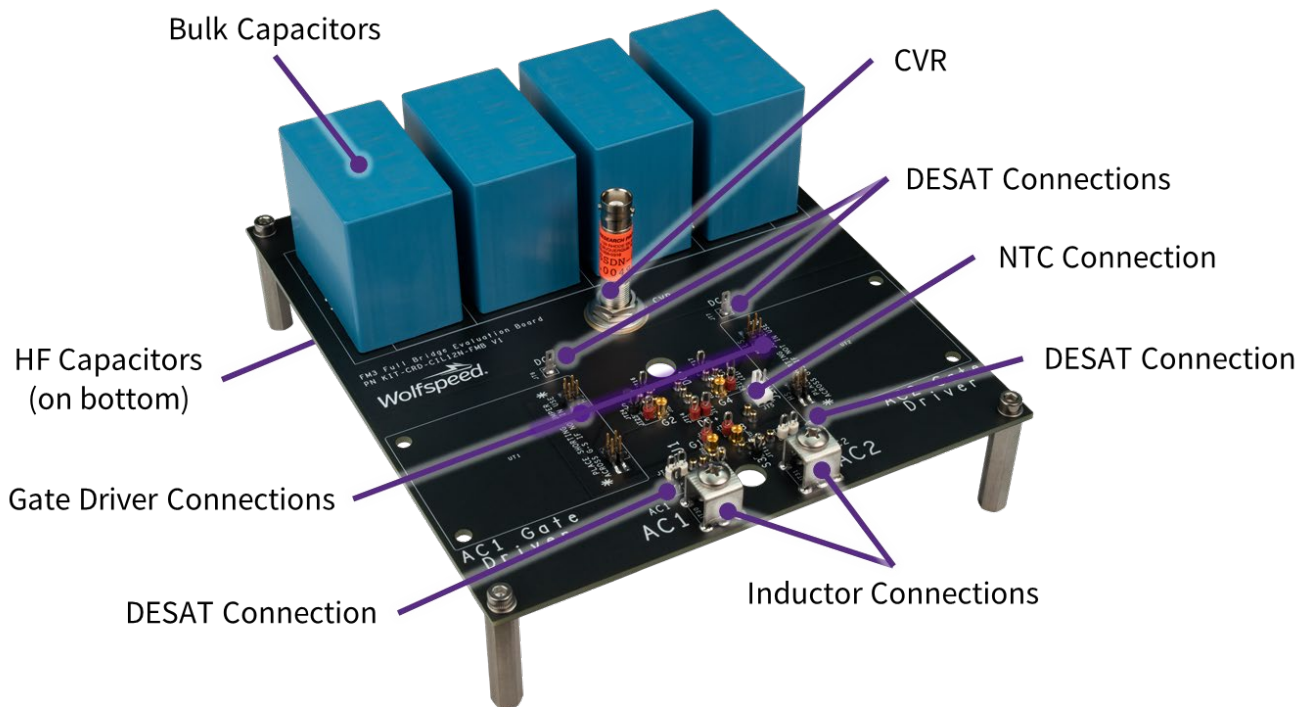

Figure 41: KIT-CRD-CIL12N-FMB CIL evaluation kit

6.9 KIT-CRD-CIL12N-FMC

The KIT-CRD-CIL12N-FMC evaluation board, shown in Figure 42, can be used to characterize 1.2 kV Wolfspeed six-pack FM power modules. The configuration in Figure 42 shows a mounted FM power module and its recommended CGD1700HB2P-UNA gate driver (these are not included with the evaluation kit). The configuration shown in Figure 42 uses four parallel 1.1 kV 40 μ F bulk capacitors, thirty parallel 1.5 kV 0.047 μ F high-frequency capacitors, a 5 m Ω tubular shunt CVR, and screw terminals for attaching the load inductor. For switching measurements, attach the load inductor to the ‘+’ and ‘U (or ‘V’/‘W’), depending on the phase being tested) screw terminals, and switch the low-side MOSFET. For reverse recovery measurements, attach the load inductor to the ‘-’ and ‘U (or ‘V’/‘W’), depending on the phase being tested) screw terminals and switch the high-side MOSFET. Here, the ‘+’ and ‘-’ labels refer to the screw terminals located behind the bulk capacitors (there are two + and two – terminals that may be used interchangeably). Drain-source voltage measurements on the high and low side can be measured using the test points located on the PCB. Gate driver connections are broken out for each phase leg of the six-pack module and jumpers are used to keep unused switch positions off. Gate-source voltage measurements can be measured on the gate driver or by the ‘HS VGS’ and ‘LS VGS’ regions on the PCB. The input leads from the high-voltage power supply should be connected to the ‘+’ and ‘-’ terminals located behind the bulk capacitors.

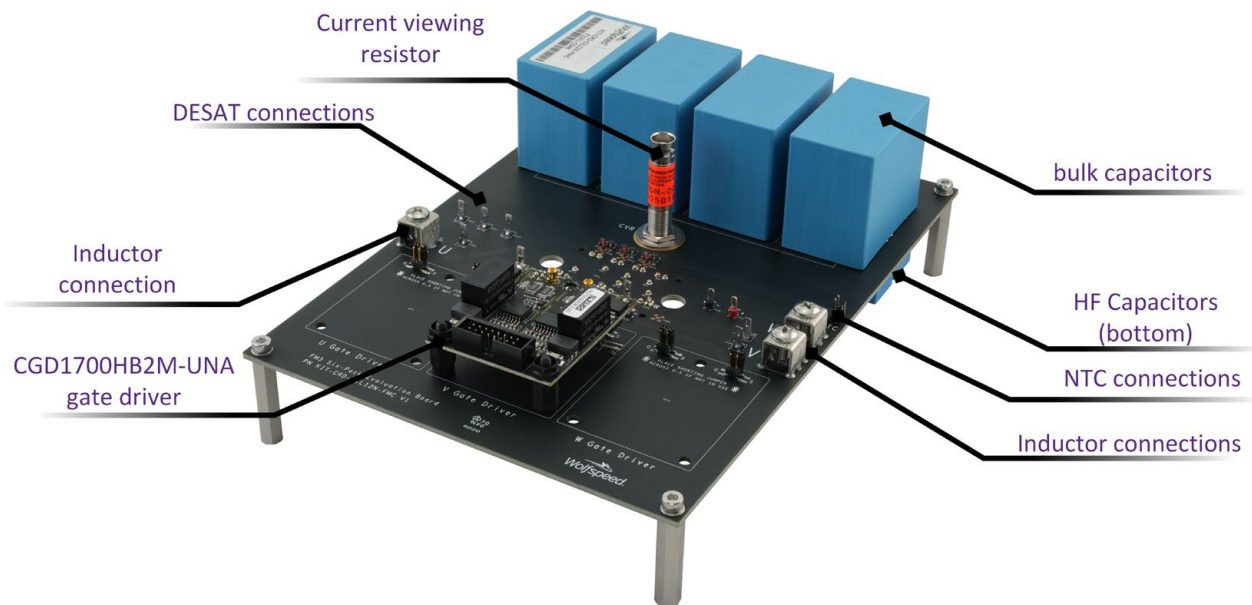

Figure 42: KIT-CRD-CIL12N-FMC CIL Evaluation Board

6.10 KIT-CRD-CIL12N-GMA

The KIT-CRD-CIL12N-GMA evaluation board, shown in Figure 43, can be used to characterize 1.2 kV Wolfspeed half-bridge GM power modules. The configuration in Figure 43 shows a mounted GM power module and its recommended CGD1700HB2P-UNA gate driver (these are not included with the evaluation kit). The configuration shown in Figure 43 uses a single 1.1 kV 200 μ F bulk capacitor, thirty parallel 1.5 kV 0.047 μ F high-frequency capacitors, a 5 m Ω tubular CVR, and screw terminals for attaching the load inductor. For switching measurements, attach the load inductor to the ‘+’ and ‘MID’ screw terminals, and switch the low-side MOSFET. For reverse recovery measurements, attach the load inductor to the ‘-’ and ‘MID’ screw terminals and switch the high-side MOSFET. Here, the ‘+’ and ‘-’ labels refer to the screw terminals located behind the bulk capacitor (there are two + and two – terminals that may be used interchangeably). Drain-source voltage measurements on the high and low side can be measured using the test points located on the PCB. Gate-source voltage measurements can be measured on the gate driver or by the ‘HS VGS’ and ‘LS VGS’ regions on the PCB. The input leads from the high-voltage power supply should be connected to the ‘+’ and ‘-’ terminals located behind the bulk capacitor.

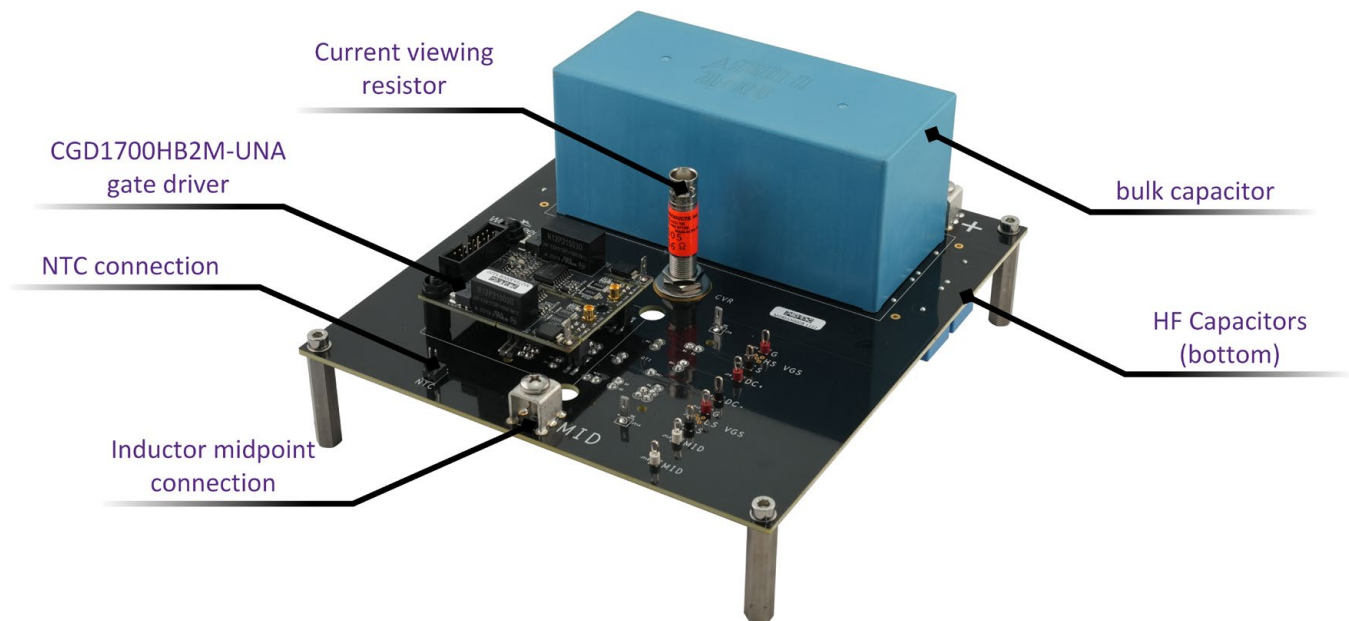

Figure 43: KIT-CRD-CIL12N-GMA CIL Evaluation Board

6.11 KIT-CRD-CIL23N-GMA

The KIT-CRD-CIL23N-GMA evaluation board, shown in Figure 44, can be used to characterize 2.3 kV Wolfspeed half-bridge GM power modules. The configuration in Figure 44 shows a mounted GM power module and its recommended CGD1700HB2P-UNA gate driver (these are not included with the evaluation kit). The configuration shown in Figure 44 uses three 1.5 kV 40 μ F bulk capacitors, twenty-six parallel 2.0 kV 4.7 nF high-frequency capacitors, a tubular CVR, and screw terminals for attaching the load inductor. For switching measurements, attach the load inductor to the '+' and 'PH' screw terminals, and switch the low-side MOSFET. For reverse recovery measurements, attach the load inductor to the '-' and 'PH' screw terminals and switch the high-side MOSFET. Here, the '+' and '-' labels refer to the screw terminals located behind the bulk capacitor (there are two + and two - terminals that may be used interchangeably). Drain-source voltage measurements on the high and low side can be measured using the test points located on the PCB. Gate-source voltage measurements can be measured on the gate driver or by the 'G1' (high-side) and 'G2' (low-side) test points on the PCB. The input leads from the high-voltage power supply should be connected to the '+' and '-' terminals located behind the bulk capacitor. Pads for 3640 SMD ceramic capacitors and 2512 SMD resistors are included for optional RC snubber evaluation.

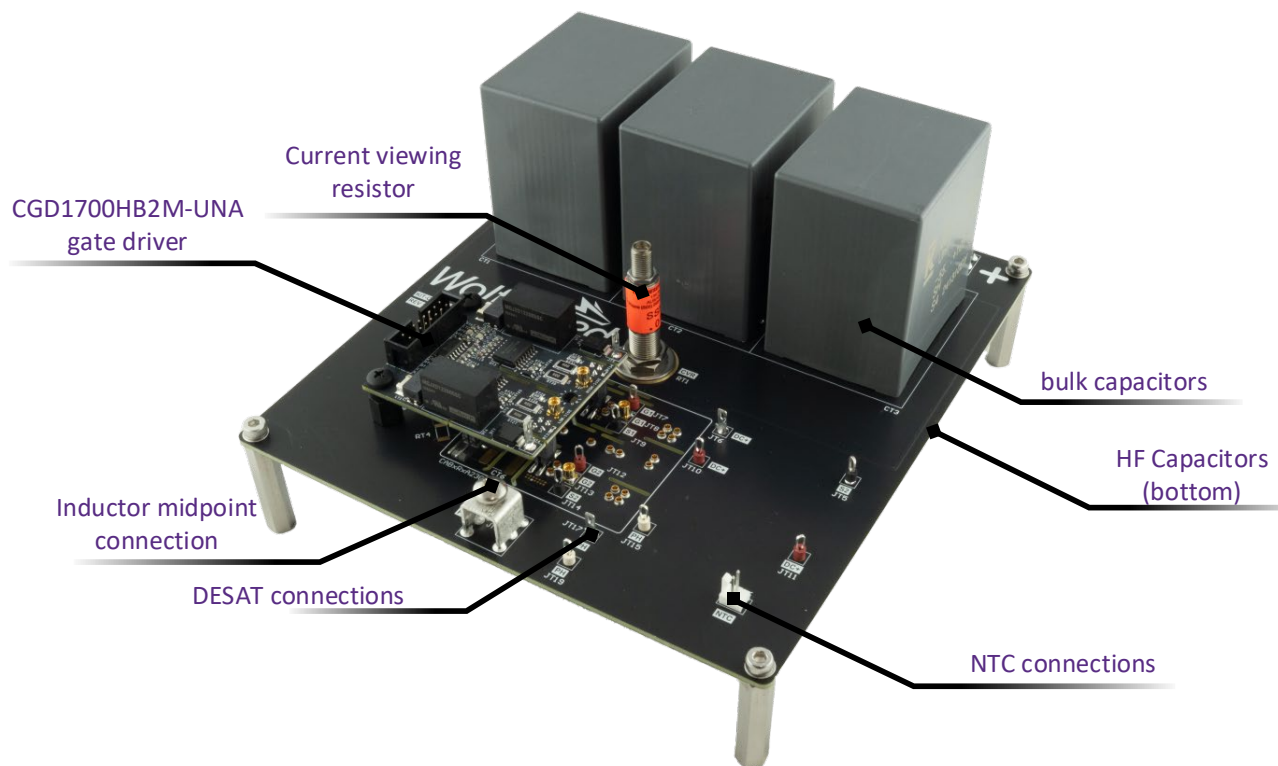

Figure 44. KIT-CRD-CIL23N-GMA Evaluation Board

6.12 KIT-CRD-CIL17N-DM

The KIT-CRD-CIL17N-DM evaluation board, shown in Figure 45, can be used to characterize 1.2 kV Wolfspeed half-bridge DM power modules. The configuration in Figure 45 shows a mounted DM power module and its recommended CGD1700HB2P-UNA gate driver (these are not included with the evaluation kit). The configuration shown in Figure 45 uses four parallel 1.5 kV 40 μ F bulk capacitors, thirty parallel 1.5 kV 0.047 μ F high-frequency capacitors, a 5 m Ω tubular CVR, and screw terminals for attaching the load inductor. For switching measurements, attach the load inductor to the '+' and 'MID' screw terminals, and switch the low-side MOSFET. For reverse recovery measurements, attach the load inductor to the '-' and 'MID' screw terminals and switch the high-side MOSFET. Here, the '+' and '-' labels refer to the screw terminals located behind the bulk capacitor (there are two + and two - terminals that may be used interchangeably). Drain-source voltage measurements on the high and low side can be measured using the test points located on the PCB. Gate-source voltage measurements can be measured on the gate driver or by the 'HS VGS' and 'LS VGS' regions on the PCB. The input leads from the high-voltage power supply should be connected to the '+' and '-' terminals located behind the bulk capacitors.

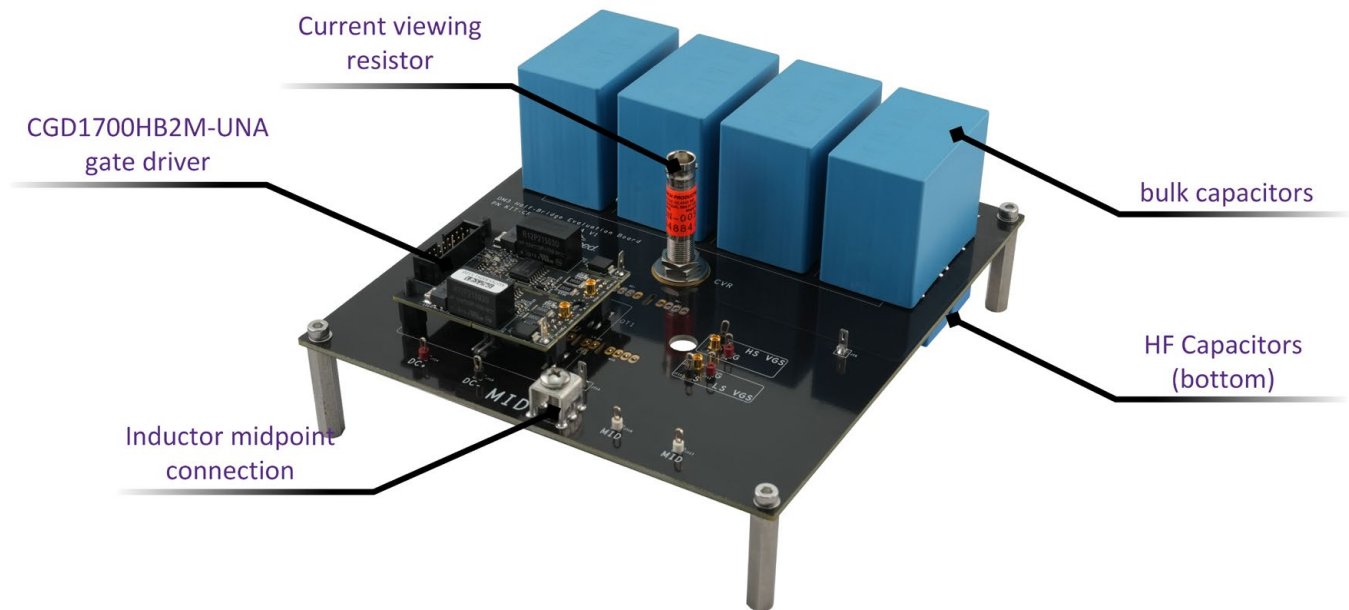

Figure 45: KIT-CRD-CIL17N-DM CIL Evaluation Board

6.13 KIT-CRD-CIL12N-YMC

The KIT-CRD-CIL12N-YMC evaluation board, shown in Figure 46, can be used to characterize 1.2 kV Wolfspeed Six-pack YM power modules. The configuration in Figure 46 shows a mounted YM power module and its recommended CGD1700HB2P-UNA gate driver (these are not included with the evaluation kit). The configuration shown in Figure 46 uses five parallel 1.1 kV 40 μ F bulk capacitors, thirty parallel 1.1 kV 0.1 μ F high-frequency capacitors, a 2.5 m Ω bar shunt CVR, and screw terminals for attaching the load inductor. For switching measurements, attach the load inductor to the '+' and the AC terminal of the power module, and switch the low-side MOSFET. For reverse recovery measurements, attach the load inductor to the '-' and the AC terminal of the power module and switch the high-side MOSFET. Here, the '+' and '-' labels refer to the screw terminals located behind the bulk capacitor (there are two + and two - terminals that may be used interchangeably). Drain-source voltage measurements on the high and low side can be measured using the test points located on the gate driver adapter PCB. Gate-source voltage measurements can be measured on the gate driver or by the 'HS VGS' and 'LS VGS' regions on the gate driver adapter PCB. The input leads from the high-voltage power supply should be connected to the '+' and '-' terminals located behind the bulk capacitors.

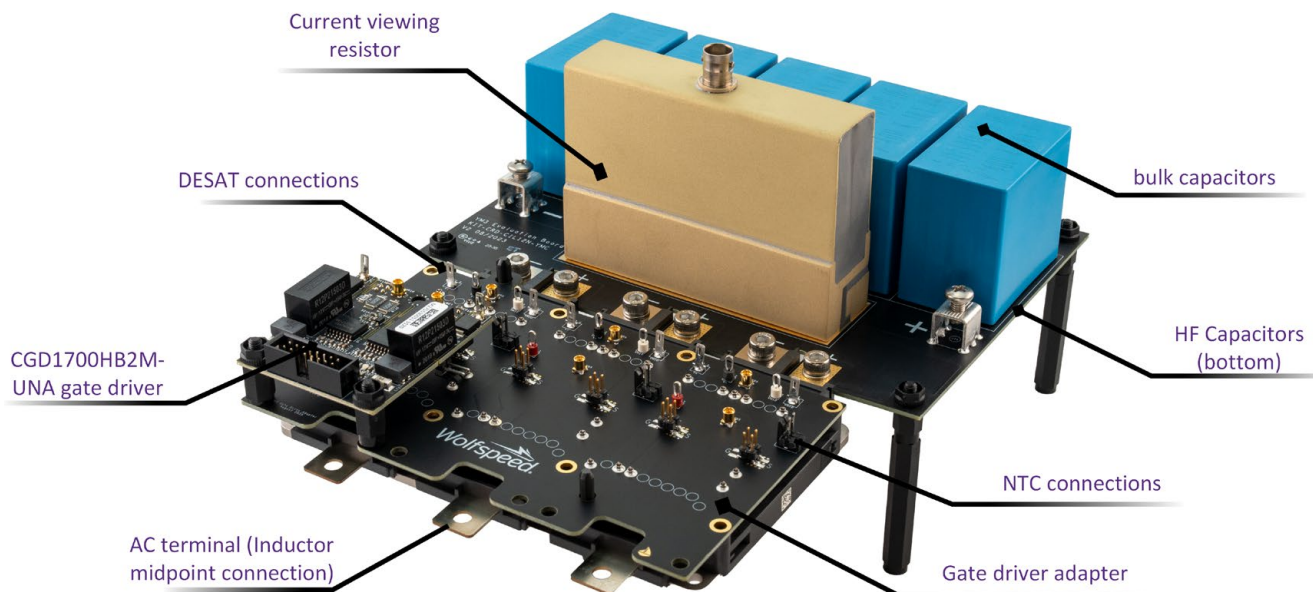

Figure 46: KIT-CRD-CIL12N-YMC CIL Evaluation Board

Revision History

Date	Revision	Changes
January 2024	1	Initial Release
October 2024	2	Added KIT-CRD-CIL23N-GMA Adjusted instruction wording
February 2025	3	Added KIT-CRD-CIL12N-YMC

Important Notes

Purposes and Use

Wolfspeed, Inc. (on behalf of itself and its affiliates, “Wolfspeed”) reserves the right in its sole discretion to make corrections, enhancements, improvements, or other changes to the board or to discontinue the board.

THE BOARD DESCRIBED IS AN ENGINEERING TOOL INTENDED SOLELY FOR LABORATORY USE BY HIGHLY QUALIFIED AND EXPERIENCED ELECTRICAL ENGINEERS TO EVALUATE THE PERFORMANCE OF WOLFSPEED POWER SWITCHING DEVICES. THE BOARD SHOULD NOT BE USED AS ALL OR PART OF A FINISHED PRODUCT. THIS BOARD IS NOT SUITABLE FOR SALE TO OR USE BY CONSUMERS AND CAN BE HIGHLY DANGEROUS IF NOT USED PROPERLY. THIS BOARD IS NOT DESIGNED OR INTENDED TO BE INCORPORATED INTO ANY OTHER PRODUCT FOR RESALE. THE USER SHOULD CAREFULLY REVIEW THE DOCUMENT TO WHICH THESE NOTIFICATIONS ARE ATTACHED AND OTHER WRITTEN USER DOCUMENTATION THAT MAY BE PROVIDED BY WOLFSPEED (TOGETHER, THE “DOCUMENTATION”) PRIOR TO USE. USE OF THIS BOARD IS AT THE USER’S SOLE RISK.

Operation of Board

It is important to operate the board within Wolfspeed’s recommended specifications and environmental considerations as described in the Documentation. Exceeding specified ratings (such as input and output voltage, current, power, or environmental ranges) may cause property damage. If you have questions about these ratings, please contact Wolfspeed prior to connecting interface electronics (including input power and intended loads). Any loads applied outside of a specified output range may result in adverse consequences, including unintended or inaccurate evaluations or possible permanent damage to the board or its interfaced electronics. Please consult the Documentation prior to connecting any load to the board. If you have any questions about load specifications for the board, please contact Wolfspeed at forum.wolfspeed.com for assistance.

Users should ensure that appropriate safety procedures are followed when working with the board as serious injury, including death by electrocution or serious injury by electrical shock or electrical burns can occur if you do not follow proper safety precautions. It is not necessary in proper operation for the user to touch the board while it is energized. When devices are being attached to the board for testing, the board must be disconnected from the electrical source and any bulk capacitors must be fully discharged. When the board is connected to an electrical source and for a short time thereafter until board components are fully discharged, some board components will be electrically charged and/or have temperatures greater than 50° Celsius. These

components may include bulk capacitors, connectors, linear regulators, switching transistors, heatsinks, resistors and SiC diodes that can be identified using board schematic. Users should contact Wolfspeed for assistance if a board schematic is not included in the Documentation or if users have questions about a board's components. When operating the board, users should be aware that these components will be hot and could electrocute or electrically shock the user. As with all electronic evaluation tools, only qualified personnel knowledgeable in handling electronic performance evaluation, measurement, and diagnostic tools should use the board.

User Responsibility for Safe Handling and Compliance with Laws

Users should read the Documentation and, specifically, the various hazard descriptions and warnings contained in the Documentation, prior to handling the board. The Documentation contains important safety information about voltages and temperatures.

Users assume all responsibility and liability for the proper and safe handling of the board. Users are responsible for complying with all safety laws, rules, and regulations related to the use of the board. Users are responsible for (1) establishing protections and safeguards to ensure that a user's use of the board will not result in any property damage, injury, or death, even if the board should fail to perform as described, intended, or expected, and (2) ensuring the safety of any activities to be conducted by the user or the user's employees, affiliates, contractors, representatives, agents, or designees in the use of the board. User questions regarding the safe usage of the board should be directed to Wolfspeed at forum.wolfspeed.com.

In addition, users are responsible for:

- compliance with all international, national, state, and local laws, rules, and regulations that apply to the handling or use of the board by a user or the user's employees, affiliates, contractors, representatives, agents, or designees.
- taking necessary measures, at the user's expense, to correct radio interference if operation of the board causes interference with radio communications. The board may generate, use, and/or radiate radio frequency energy, but it has not been tested for compliance within the limits of computing devices pursuant to Federal Communications Commission or Industry Canada rules, which are designed to provide protection against radio frequency interference.
- compliance with applicable regulatory or safety compliance or certification standards that may normally be associated with other products, such as those established by EU Directive 2011/65/EU of the European Parliament and of the Council on 8 June 2011 about the Restriction of Use of Hazardous Substances (or the RoHS 2 Directive) and EU Directive 2002/96/EC on Waste Electrical and Electronic Equipment (or WEEE). The board is not a finished end product and therefore may not meet such standards. Users are also responsible for properly disposing of a board's components and materials.

No Warranty

THE BOARD IS PROVIDED "AS IS" WITHOUT WARRANTY OF ANY KIND, INCLUDING BUT NOT LIMITED TO ANY WARRANTY OF NON-INFRINGEMENT, MERCHANTABILITY, OR FITNESS FOR A PARTICULAR PURPOSE, WHETHER

EXPRESS OR IMPLIED. THERE IS NO REPRESENTATION THAT OPERATION OF THIS BOARD WILL BE UNINTERRUPTED OR ERROR FREE.

Limitation of Liability

IN NO EVENT SHALL WOLFSPEED BE LIABLE FOR ANY DAMAGES OF ANY KIND ARISING FROM USE OF THE BOARD. WOLFSPEED'S AGGREGATE LIABILITY IN DAMAGES OR OTHERWISE SHALL IN NO EVENT EXCEED THE AMOUNT, IF ANY, RECEIVED BY WOLFSPEED IN EXCHANGE FOR THE BOARD. IN NO EVENT SHALL WOLFSPEED BE LIABLE FOR INCIDENTAL, CONSEQUENTIAL, OR SPECIAL LOSS OR DAMAGES OF ANY KIND, HOWEVER CAUSED, OR ANY PUNITIVE, EXEMPLARY, OR OTHER DAMAGES. NO ACTION, REGARDLESS OF FORM, ARISING OUT OF OR IN ANY WAY CONNECTED WITH ANY BOARD FURNISHED BY WOLFSPEED MAY BE BROUGHT AGAINST WOLFSPEED MORE THAN ONE (1) YEAR AFTER THE CAUSE OF ACTION ACCRUED.

Indemnification

The board is not a standard consumer or commercial product. As a result, any indemnification obligations imposed upon Wolfspeed by contract with respect to product safety, product liability, or intellectual property infringement do not apply to the board.