

WAB300M12BM3

1200 V, 300 A All-Silicon Carbide
THB-80 Qualified, Switching Optimized, Half-Bridge Module

V_{DS}	1200 V
I_{DS}	300 A

Technical Features

- Industry Standard 62 mm Footprint
- High Humidity Operation THB-80 (HV-H3TRB)
- High Junction Temperature (175 °C) Operation
- Implements Switching Optimized Third Generation SiC MOSFET Technology
- Low Inductance (10.2 nH) Design
- Silicon Nitride Insulator and Copper Baseplate

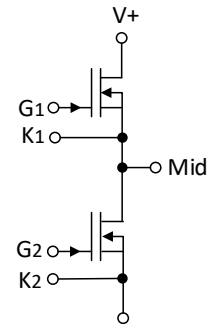

Applications

- Railway & Traction
- Solar
- EV Chargers
- Industrial Automation & Testing

System Benefits

- Fast Time-to-Market with Minimal Development Required for Transition from 62 mm Si IGBT Packages
- Increased System Efficiency, due to Low Switching & Conduction Losses of SiC
- High Reliability Material Selection

Key Parameters

Parameter	Symbol	Min.	Typ.	Max.	Unit	Conditions	Note
Drain-Source Voltage	V_{DS}			1200	V	$T_C = 25\text{ }^\circ\text{C}$	
Gate-Source Voltage, Maximum Value	$V_{GS(max)}$	-8		+19		Transient	Note 1 Fig. 32
Gate-Source Voltage, Recommended	$V_{GS(op)}$		-4/+15			Static	
DC Continuous Drain Current	I_D		382		A	$V_{GS} = 15\text{ V}, T_C = 25\text{ }^\circ\text{C}, T_{VJ} \leq 175\text{ }^\circ\text{C}$	Notes 2, 3 Fig. 20
DC Source-Drain Current (Body Diode)			190			$V_{GS} = 15\text{ V}, T_C = 90\text{ }^\circ\text{C}, T_{VJ} \leq 175\text{ }^\circ\text{C}$	
Pulsed Drain-Source Current	I_{DM}		600			$V_{GS} = -4\text{ V}, T_C = 25\text{ }^\circ\text{C}, T_{VJ} \leq 175\text{ }^\circ\text{C}$	
						t_{Pmax} limited by T_{VJmax} $V_{GS} = 15\text{ V}, T_C = 25\text{ }^\circ\text{C}$	
Power Dissipation	P_D		938		W	$T_C = 25\text{ }^\circ\text{C}, T_{VJ} \leq 175\text{ }^\circ\text{C}$	Note 4 Fig. 20
Virtual Junction Temperature	$T_{VJ(op)}$	-40		175	$^\circ\text{C}$		

Note (1): Recommended turn-on gate voltage is 15 V with $\pm 5\%$ regulation tolerance

Note (2): Current limit at $T_C = 90\text{ }^\circ\text{C}$ calculated by $I_{D(max)} = \sqrt{(P_D/R_{DS(typ)})(T_{VJ(max)} - T_{VJ(max)})}$

Note (3): Verified by design

Note (4): $P_D = (T_{VJ} - T_C)/R_{TH(JC,typ)}$

MOSFET Characteristics (Per Position) ($T_{VJ} = 25\text{ }^{\circ}\text{C}$ Unless Otherwise Specified)

Parameter	Symbol	Min.	Typ.	Max.	Unit	Conditions	Note	
Drain-Source Breakdown Voltage	$V_{(BR)DSS}$	1200				$V_{GS} = 0\text{ V}, T_{VJ} = -40\text{ }^{\circ}\text{C}$		
Gate Threshold Voltage	$V_{GS(th)}$	1.8	2.5	3.6	V	$V_{DS} = V_{GS}, I_D = 92\text{ mA}$		
			2.0			$V_{DS} = V_{GS}, I_D = 92\text{ mA}, T_{VJ} = 175\text{ }^{\circ}\text{C}$		
Zero Gate Voltage Drain Current	I_{DSS}		10	150	μA	$V_{GS} = 0\text{ V}, V_{DS} = 1200\text{ V}$		
Gate-Source Leakage Current	I_{GSS}		0.05	1		$V_{GS} = 15\text{ V}, V_{DS} = 0\text{ V}$		
Drain-Source On-State Resistance (Devices Only)	$R_{DS(on)}$		4.0	5.2	$\text{m}\Omega$	$V_{GS} = 15\text{ V}, I_D = 300\text{ A}$	Fig. 2 Fig. 3	
			6.4			$V_{GS} = 15\text{ V}, I_D = 300\text{ A}, T_{VJ} = 175\text{ }^{\circ}\text{C}$		
Transconductance	g_{fs}		212		S	$V_{DS} = 20\text{ V}, I_{DS} = 300\text{ A}$	Fig. 4	
			200			$V_{DS} = 20\text{ V}, I_{DS} = 300\text{ A}, T_{VJ} = 175\text{ }^{\circ}\text{C}$		
Turn-On Switching Energy, $T_J = 25\text{ }^{\circ}\text{C}$ $T_J = 125\text{ }^{\circ}\text{C}$ $T_J = 175\text{ }^{\circ}\text{C}$	E_{ON}		4.75		mJ	$V_{DS} = 600\text{ V},$ $I_D = 300\text{ A},$ $V_{GS} = -4\text{ V}/15\text{ V},$ $R_{G(ext)} = 2.0\text{ }\Omega,$ $L = 20.7\text{ }\mu\text{H}$	Fig. 11 Fig. 13	
Turn-Off Switching Energy, $T_J = 25\text{ }^{\circ}\text{C}$ $T_J = 125\text{ }^{\circ}\text{C}$ $T_J = 175\text{ }^{\circ}\text{C}$		E_{OFF}		4.99				
				5.23				5.30
Internal Gate Resistance	$R_{G(int)}$		1.4		Ω	$T_{VJ} = 25\text{ }^{\circ}\text{C}$		
Input Capacitance	C_{iss}		24.5		nF	$V_{GS} = 0\text{ V}, V_{DS} = 1000\text{ V},$ $V_{AC} = 25\text{ mV}, f = 100\text{ kHz}$	Fig. 9	
Output Capacitance	C_{oss}		0.97					
Reverse Transfer Capacitance	C_{rss}		50					pF
Gate to Source Charge	Q_{GS}		256		nC	$V_{DS} = 800\text{ V}, V_{GS} = -4\text{ V}/15\text{ V}$ $I_D = 400\text{ A}$ Per IEC60747-8-4 pg 21		
Gate to Drain Charge	Q_{GD}		308					
Total Gate Charge	Q_G		908					
FET Thermal Resistance, Junction to Case	R_{thJC}		0.16	0.18	$^{\circ}\text{C}/\text{W}$		Fig. 17	

Body Diode Characteristics (Per Position) ($T_{VJ} = 25\text{ }^{\circ}\text{C}$ Unless Otherwise Specified)

Parameter	Symbol	Min.	Typ.	Max.	Unit	Conditions	Note
Body Diode Forward Voltage	V_{SD}		6.0		V	$V_{GS} = -4\text{ V}, I_{SD} = 300\text{ A}$	Fig. 7
			5.5			$V_{GS} = -4\text{ V}, I_{SD} = 300\text{ A}, T_J = 175\text{ }^{\circ}\text{C}$	
Reverse Recovery Time	t_{RR}		36.5		ns	$V_{GS} = -4\text{ V}, I_{SD} = 300\text{ A}, V_R = 600\text{ V}$ $di_f/dt = 14.5\text{ A/ns}, T_J = 175\text{ }^{\circ}\text{C}$	
Reverse Recovery Charge	Q_{RR}		7.3		μC		
Peak Reverse Recovery Current	I_{RRM}		323		A		
Reverse Recovery Energy $T_J = 25\text{ }^{\circ}\text{C}$ $T_J = 125\text{ }^{\circ}\text{C}$ $T_J = 175\text{ }^{\circ}\text{C}$	E_{RR}		0.65		mJ	$V_{DS} = 600\text{ V}, I_D = 300\text{ A},$ $V_{GS} = -4\text{ V}/15\text{ V}, R_{G(ext)} = 2.0\text{ }\Omega,$ $L = 20.7\text{ }\mu\text{H}$	Fig. 14
			1.98				
			3.01				



Module Physical Characteristics

Parameter	Symbol	Min.	Typ.	Max.	Unit	Test Conditions
Package Resistance, M1	R_{3-1}		0.60		m Ω	$T_C = 125^\circ\text{C}$, Note 5
Package Resistance, M2	R_{1-2}		0.51			$T_C = 125^\circ\text{C}$, Note 5
Stray Inductance	L_{Stray}		10.2		nH	Between Terminals 2 and 3
Case Temperature	T_C	-40		125	$^\circ\text{C}$	
Weight	W		300		g	
Mounting Torque	M_S	4.5	5	5.5	N-m	Baseplate, M6 Bolts
		4.5	5	5.5		Power Terminals, M6 Bolts
Case Isolation Voltage	V_{isol}			5.5	kV	AC, 50 Hz, 1 min
Comparative Tracking Index	CTI		600			

Note (5): Total Effective Resistance (Per Switch Position) = MOSFET $R_{\text{DS(on)}}$ + Switch Position Package Resistance



Typical Performance

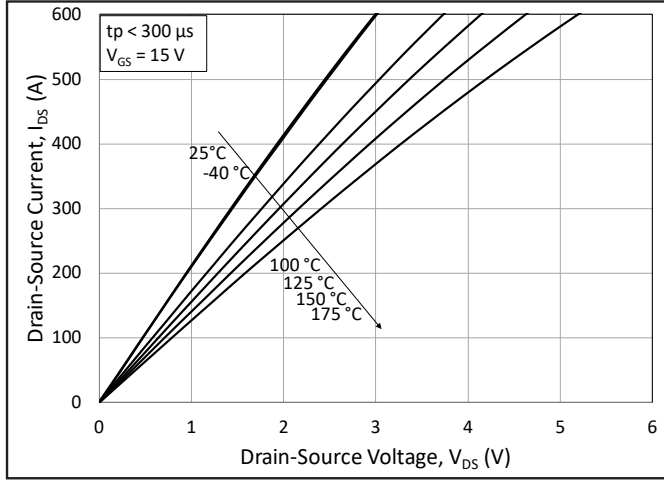

Figure 1. Output Characteristics for Various Junction Temperatures

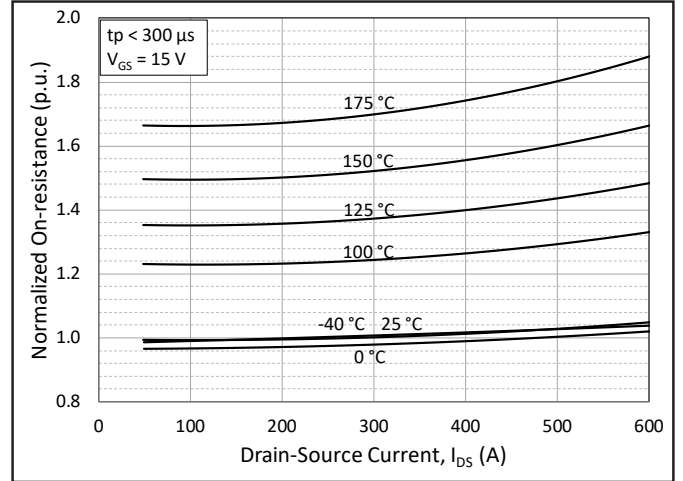

Figure 2. Normalized On-State Resistance vs. Drain Current for Various Junction Temperatures

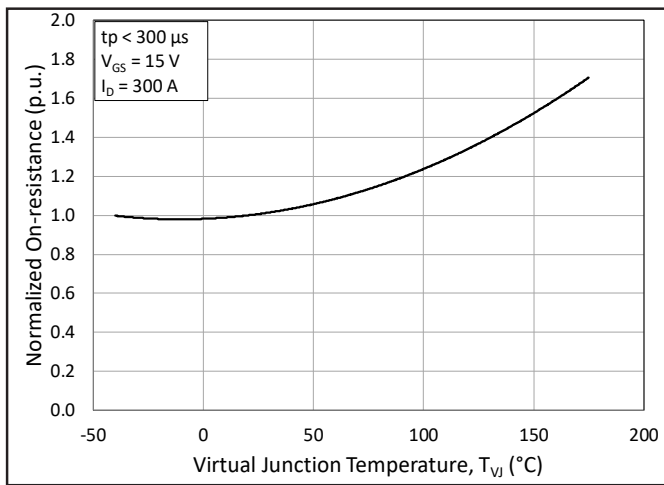

Figure 3. Normalized On-State Resistance vs. Junction Temperature

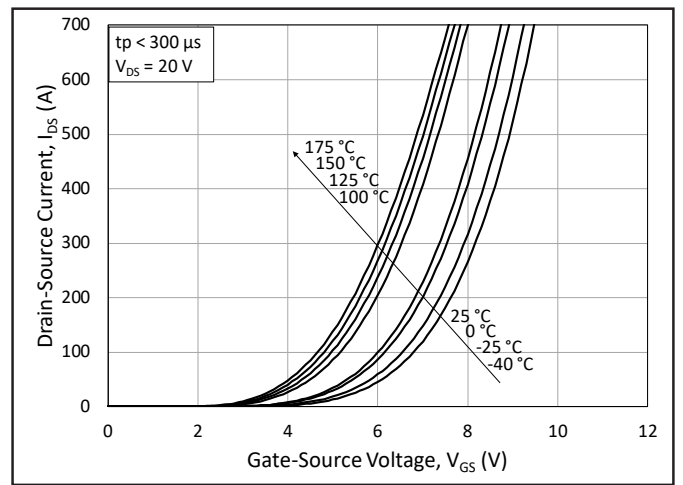

Figure 4. Transfer Characteristic for Various Junction Temperatures

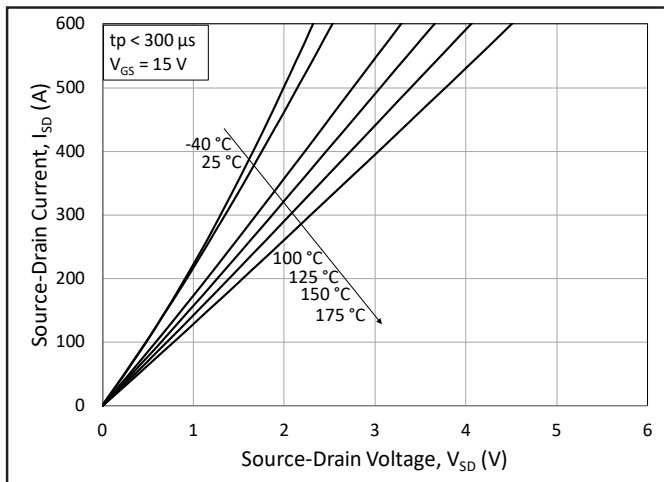

Figure 5. 3rd Quadrant Characteristic vs. Junction Temperatures at $V_{GS} = 15\text{ V}$

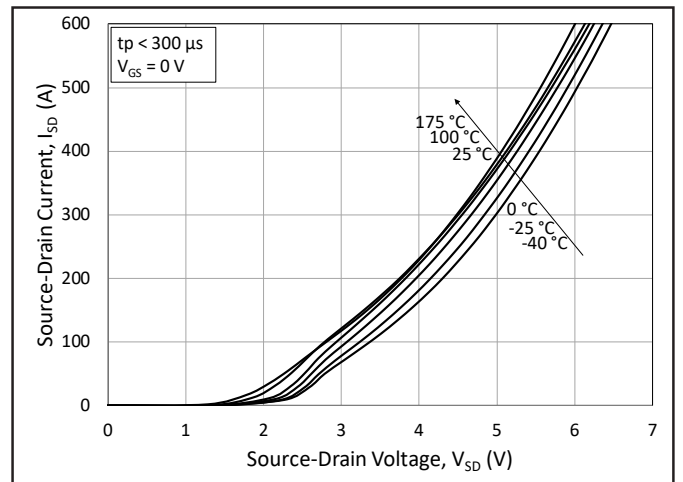

Figure 6. 3rd Quadrant Characteristic vs. Junction Temperatures at $V_{GS} = 0\text{ V}$ (Body Diode)

Typical Performance

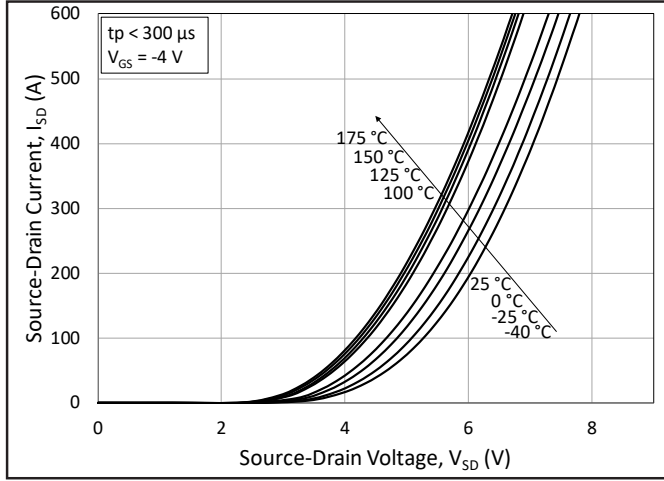

Figure 7. 3rd Quadrant Characteristic vs. Junction Temperatures at $V_{GS} = -4$ V (Body Diode)

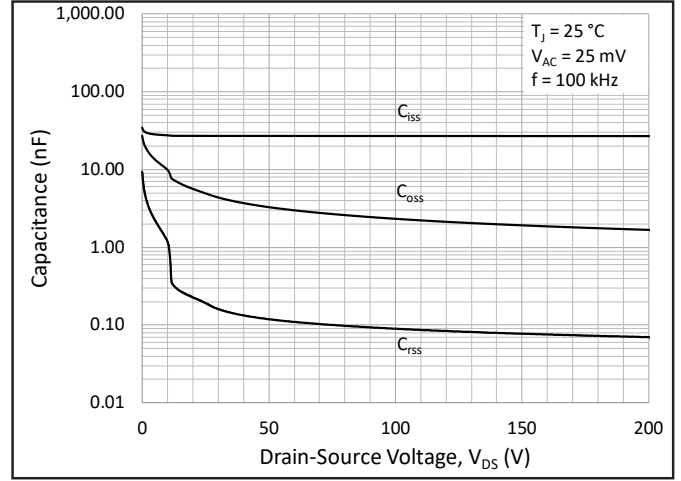

Figure 8. Typical Capacitances vs. Drain to Source Voltage (0 - 200V)

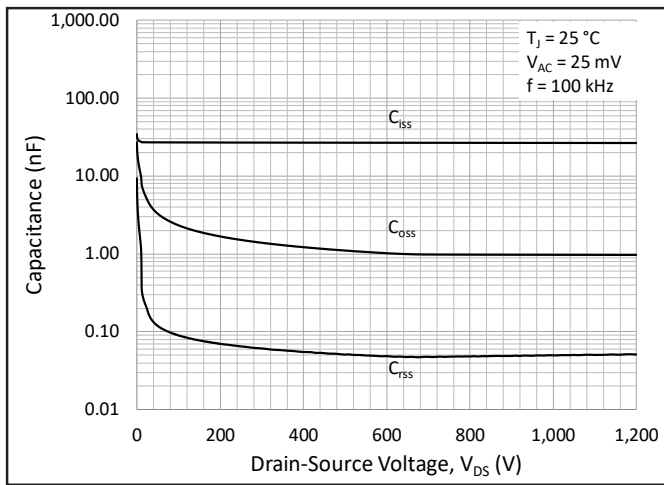

Figure 9. Typical Capacitances vs. Drain to Source Voltage (0 - 1200V)

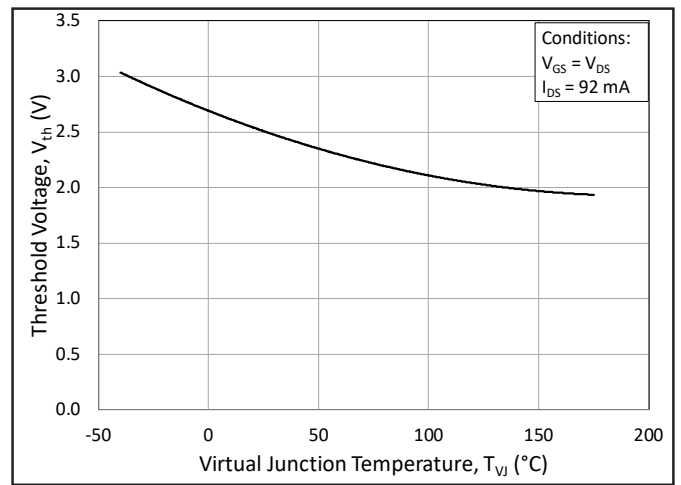

Figure 10. Threshold Voltage vs. Junction Temperature

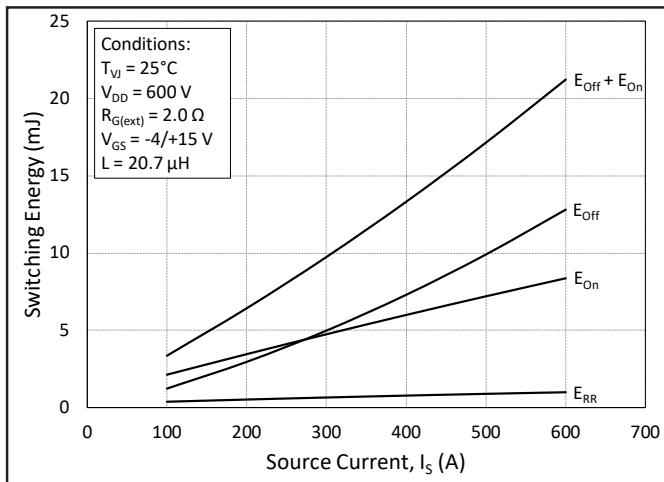

Figure 11. Switching Energy vs. Drain Current ($V_{DS} = 600$ V)

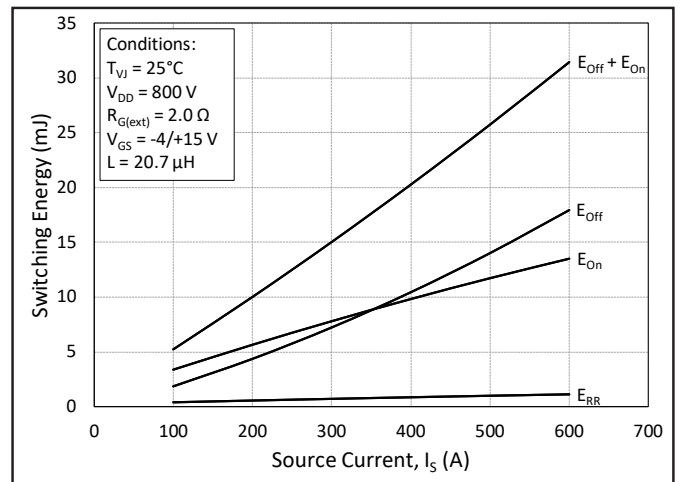

Figure 12. Switching Energy vs. Drain Current ($V_{DS} = 800$ V)



Typical Performance

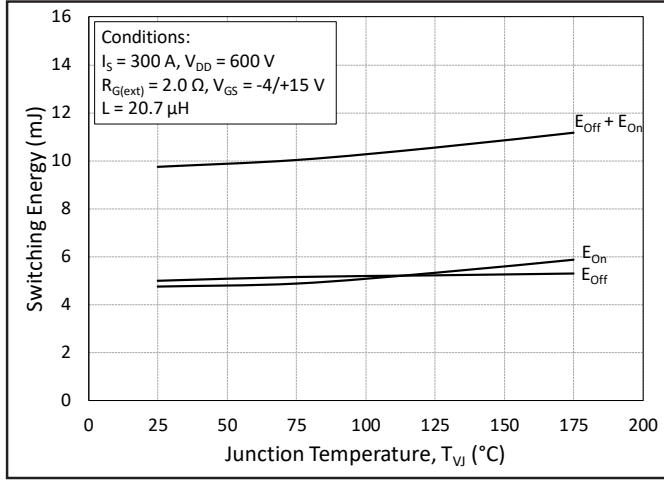

Figure 13. MOSFET Switching Energy vs. Junction Temperature

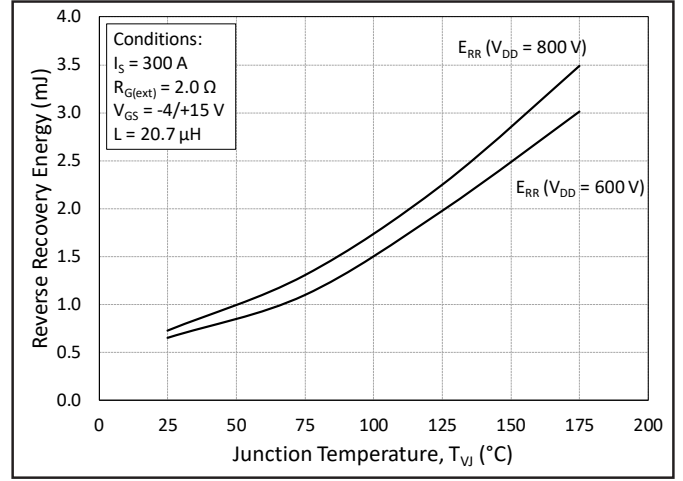

Figure 14. Reverse Recovery Energy vs. Junction Temperature

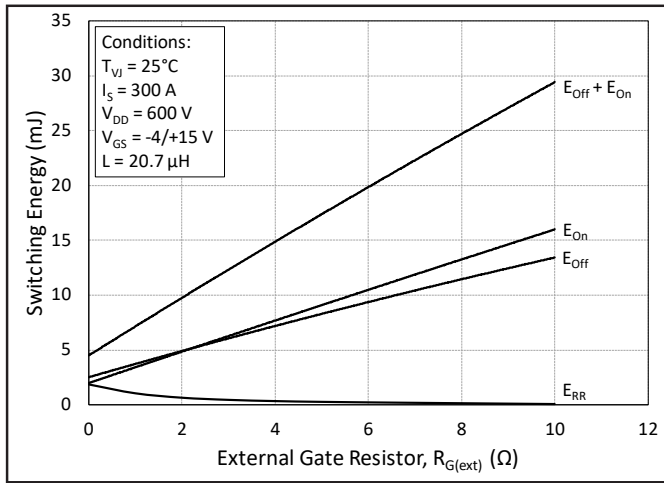

Figure 15. MOSFET Switching Energy vs. External Gate Resistance

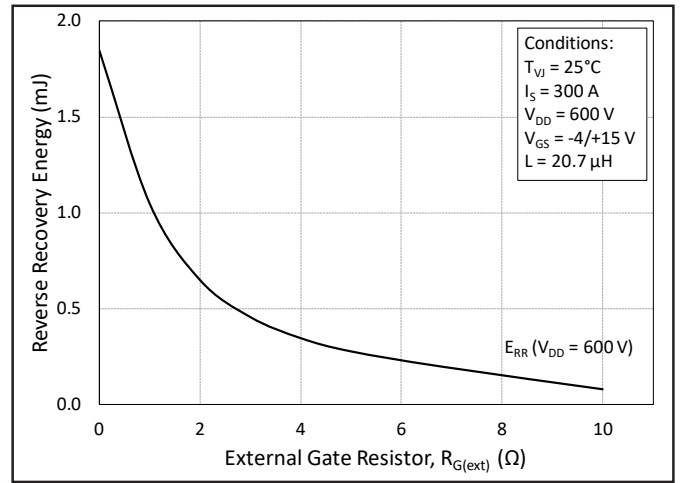

Figure 16. Reverse Recovery Energy vs. External Gate Resistance

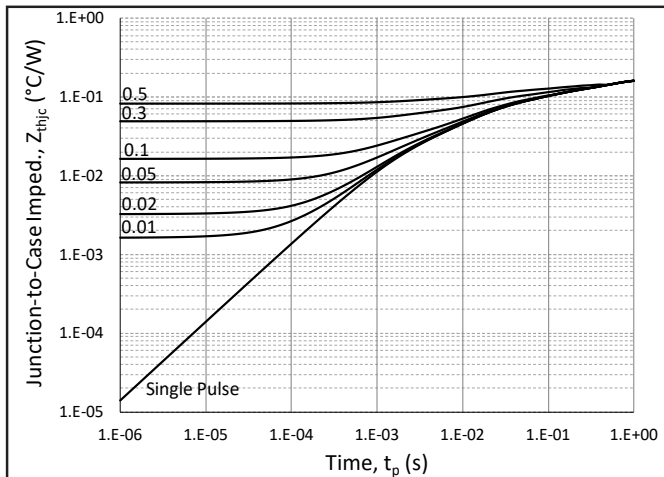

Figure 17. MOSFET Junction to Case Transient Thermal Impedance, $Z_{th(jc)}$ (°C/W)

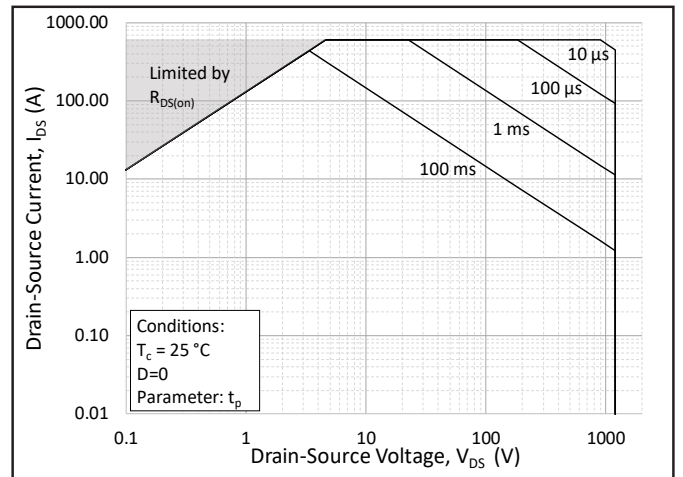

Figure 18. Forward Bias Safe Operating Area (FBSOA)



Typical Performance

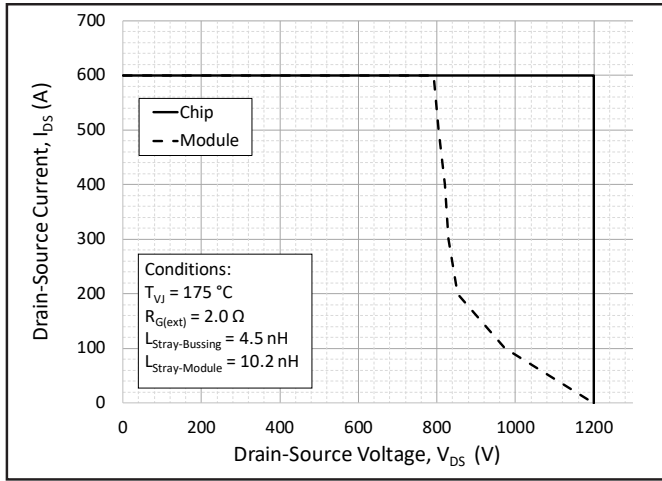

Figure 19. Reverse Bias Safe Operating Area (RBSOA)

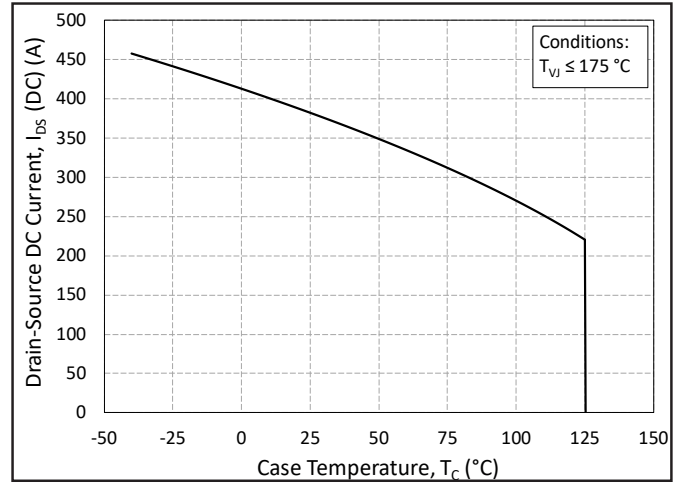

Figure 20. Continuous Drain Current Derating vs. Case Temperature

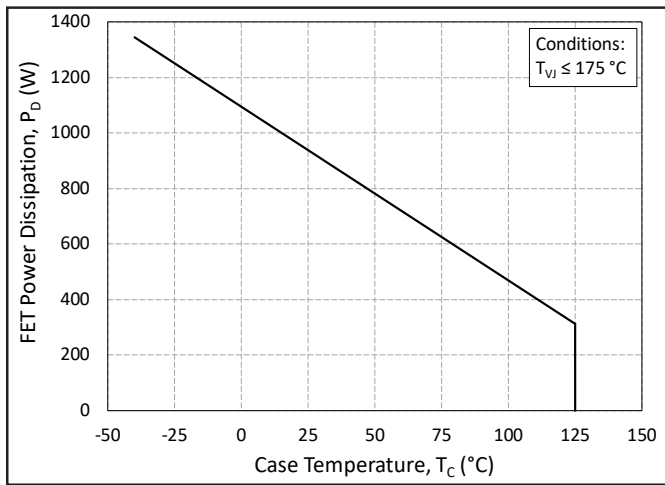

Figure 21. Maximum Power Dissipation Derating vs. Case Temperature

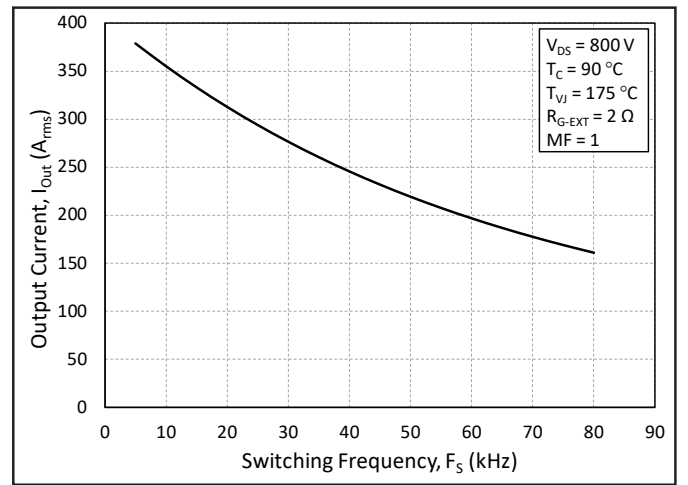

Figure 22. Typical Output Current Capability vs. Switching Frequency (Inverter Application)



Timing Characteristics

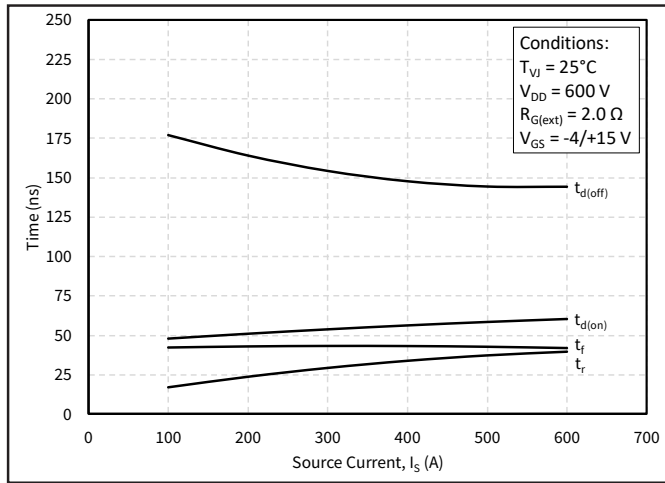

Figure 23. Timing vs. Source Current

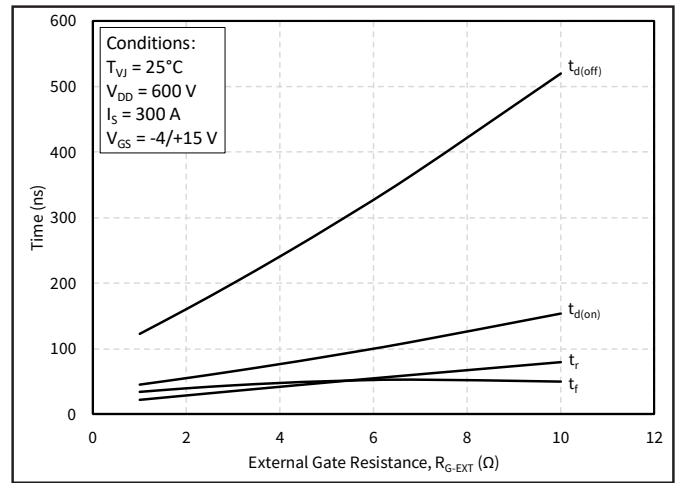

Figure 24. Timing vs. External Gate Resistance

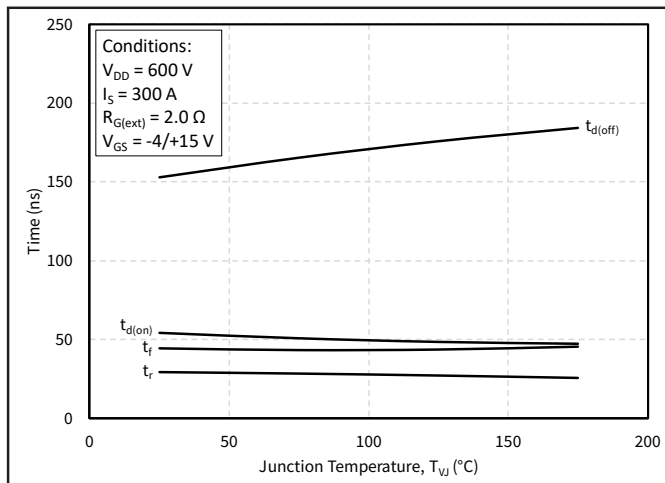

Figure 25. Timing vs. Junction Temperature

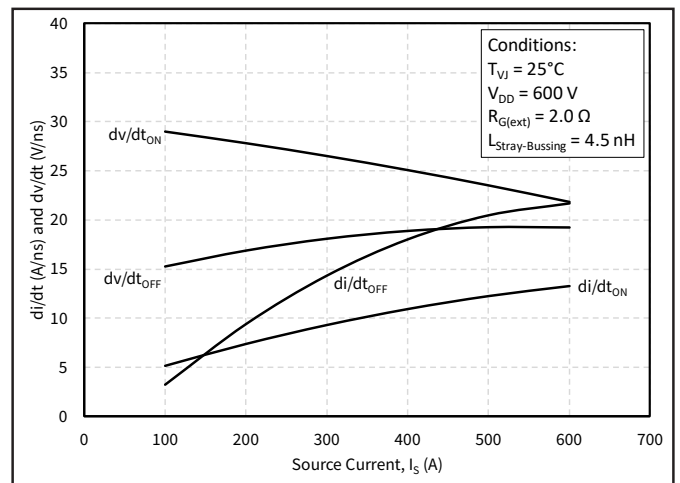

Figure 26. dv/dt and di/dt vs. Source Current

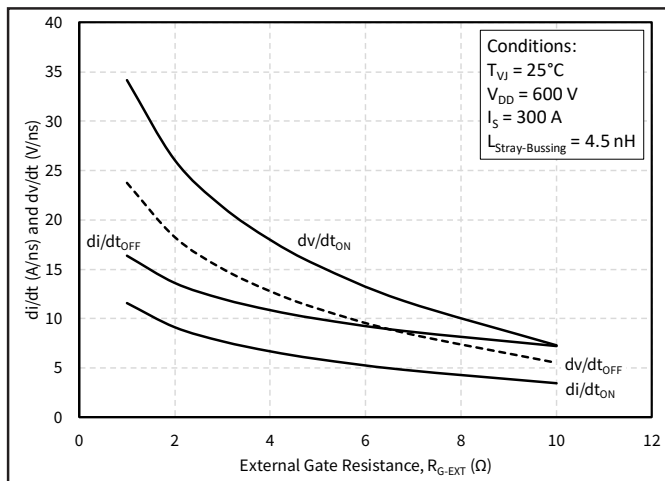

Figure 27. dv/dt and di/dt vs. External Gate Resistance

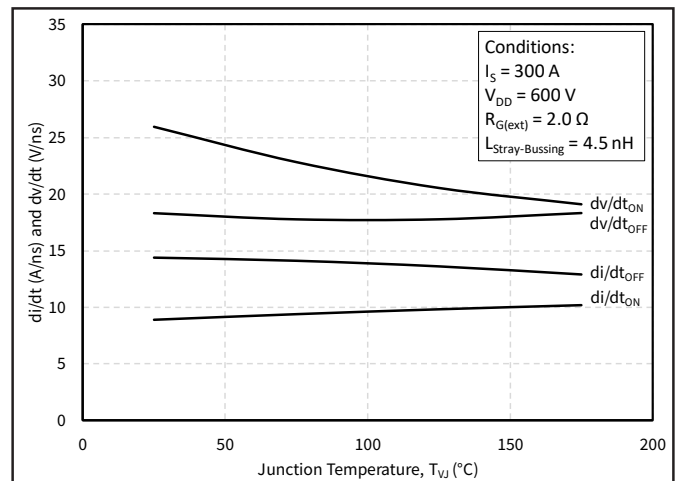

Figure 28. dv/dt and di/dt vs. Junction Temperature



Definitions

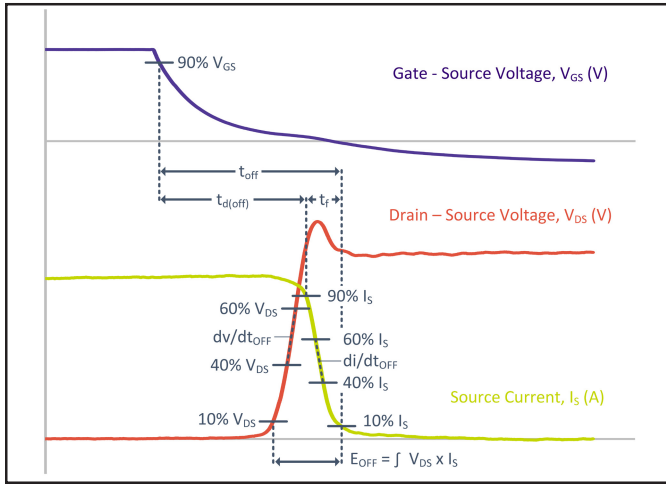

Figure 29. Turn-Off Transient Definitions

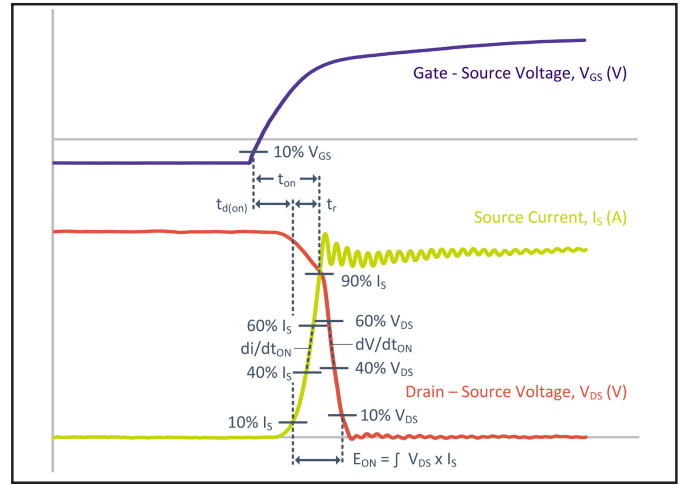

Figure 30. Turn-On Transient Definitions

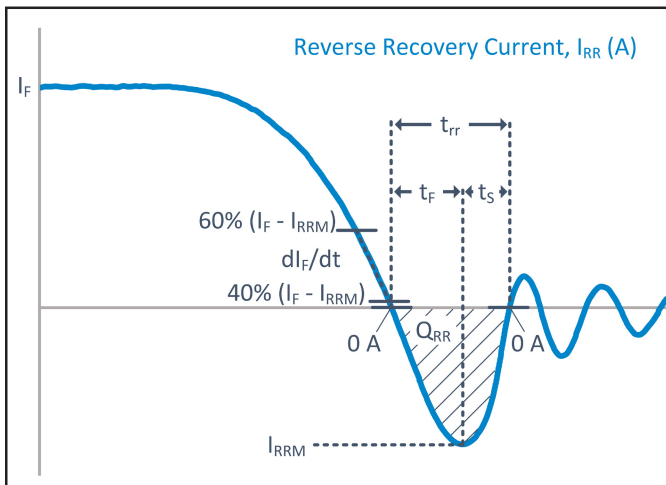

Figure 31. Reverse Recovery Definitions

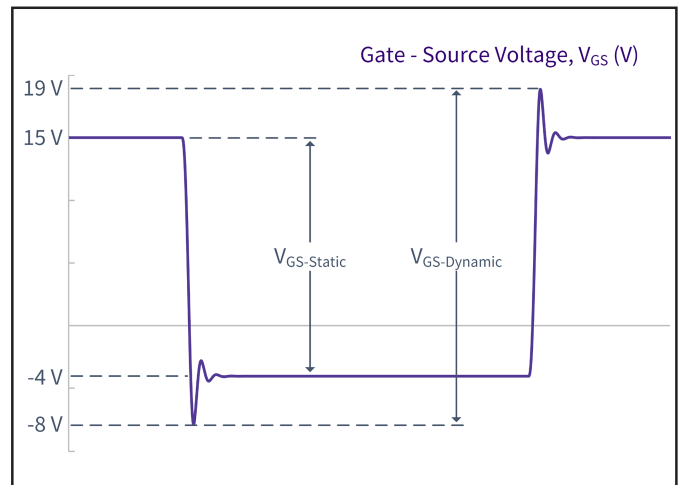
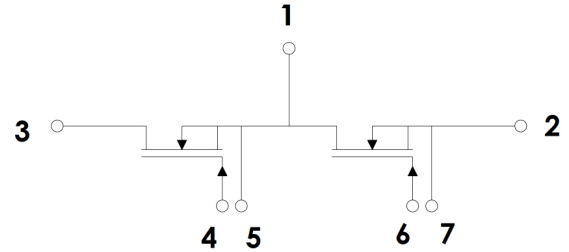
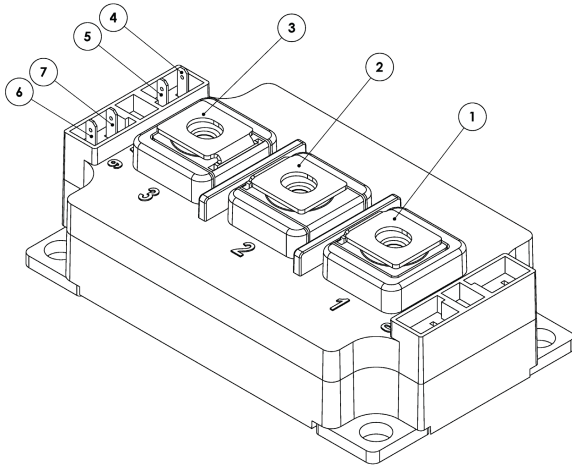

Figure 32. V_{GS} Transient Definitions



Schematic and Pin Out



Package Dimensions (mm)

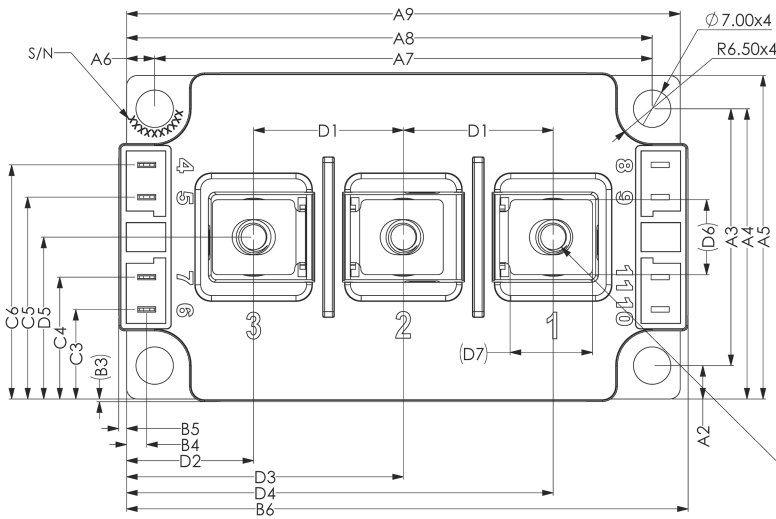

DIMENSION TABLE		
SYMBOL	DIMENSION (mm)	TOLERANCE (mm)
A1	3.00	+0.30
A2	6.22	+0.30
A3	48.00	+0.30
A4	54.22	+0.30
A5	60.44	+0.30
A6	5.25	+0.30
A7	93	+0.30
A8	98.25	+0.30
A9	103.50	+0.30
B1	22.75	+0.30
B2	27.30	+0.30
B3	0.51 x 2	REF
B4	3.76	+0.40
B5	1.25	+0.40
B6	105.00	+0.30
C1	30.60	+0.50
C2	31.40	+0.40
C3	16.72	+0.40
C4	22.75	+0.40
C5	37.7	+0.40
C6	43.73	+0.40
D1	28.00	+0.50
D2	24.20	+0.40
D3	52.00	+0.40
D4	79.80	+0.40
D5	30.22	+0.40
D6	14.00 x 3	REF
D7	15.40 x 3	REF

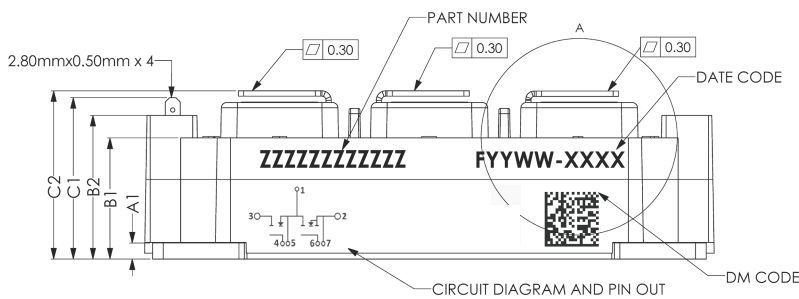

M6x6mm HEX NUT x 3
MAXIMUM BOLT PENETRATION DEPTH: 10mm

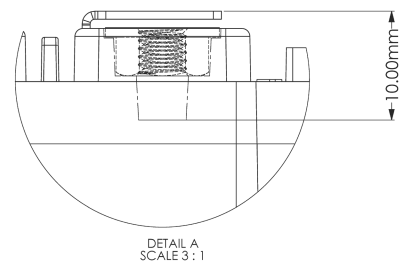



Supporting Links & Tools

- [CGD1200HB2P-BM3 Evaluation Gate Driver](#)
- [CGD12HB00D: Differential Transceiver Board](#)
- [KIT-CRD-CIL12N-BM: Dynamic Performance Evaluation Board for the BM2 & BM3 Module \(CPWR-AN-36\)](#)
- [CPWR-AN-34: Module Mounting Application Note](#)
- [CPWR-AN-35: Thermal Interface Material Application Note](#)



Notes & Disclaimer

This document and the information contained herein are subject to change without notice. Any such change shall be evidenced by the publication of an updated version of this document by Wolfspeed. No communication from any employee or agent of Wolfspeed or any third party shall effect an amendment or modification of this document. No responsibility is assumed by Wolfspeed for any infringement of patents or other rights of third parties which may result from use of the information contained herein. No license is granted by implication or otherwise under any patent or patent rights of Wolfspeed.

Notwithstanding any application-specific information, guidance, assistance, or support that Wolfspeed may provide, the buyer of this product is solely responsible for determining the suitability of this product for the buyer's purposes, including without limitation for use in the applications identified in the next bullet point, and for the compliance of the buyers' products, including those that incorporate this product, with all applicable legal, regulatory, and safety-related requirements.

This product has not been designed or tested for use in, and is not intended for use in, applications in which failure of the product would reasonably be expected to cause death, personal injury, or property damage, including but not limited to equipment implanted into the human body, life-support machines, cardiac defibrillators, and similar emergency medical equipment, aircraft navigation, communication, and control systems, aircraft power and propulsion systems, air traffic control systems, and equipment used in the planning, construction, maintenance, or operation of nuclear facilities.

RoHS Compliance

The levels of RoHS restricted materials in this product are below the maximum concentration values (also referred to as the threshold limits) permitted for such substances, or are used in an exempted application, in accordance with EU Directive 2011/65/EC (RoHS2), as implemented January 2, 2013. RoHS Declarations for this product can be obtained from your Wolfspeed representative or from the Product Documentation sections of www.wolfspeed.com.

REACH Compliance

REACH substances of high concern (SVHCs) information is available for this product. Since the European Chemical Agency (ECHA) has published notice of their intent to frequently revise the SVHC listing for the foreseeable future, please contact your Wolfspeed representative to ensure you get the most up-to-date REACH SVHC Declaration. REACH banned substance information (REACH Article 67) is also available upon request.

Contact info:

4600 Silicon Drive
Durham, NC 27703 USA
Tel: +1.919.313.5300
www.wolfspeed.com/power