

C2D10120D

1200 V, 10 A Silicon Carbide Schottky Diode

Features

- 1.2 kV Schottky rectifier
- Zero reverse recovery current
- Zero forward recovery voltage
- High-frequency operation
- Temperature-independent switching behavior
- Extremely fast switching
- Positive temperature coefficient on V_f



TO-247-3

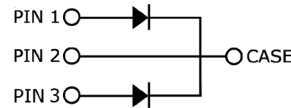

Package Types: TO-247-3

PN's: C2D10120D

Wolfspeed, Inc. is in the process of rebranding its products and related materials pursuant to the entity name change from Cree, Inc. to Wolfspeed, Inc. During this transition period, products received may be marked with either the Cree

Applications

- Switch mode power supplies
- Power factor correction
- Motor drives

Benefits

- Replace bipolar with unipolar rectifiers
- Essentially no switching losses
- Higher efficiency
- Reduction of heat sink requirements
- Parallel devices without thermal runaway

Maximum Ratings ($T_c = 25\text{ }^\circ\text{C}$ Unless Otherwise Specified)

Parameter	Symbol	Value	Unit	Test Conditions	Note
Repetitive Peak Reverse Voltage	V_{RRM}	1200	V		
Surge Peak Reverse Voltage	V_{RSM}	1200			
DC Blocking Voltage	V_{DC}	1200			
Continuous Forward Current (Per Leg/Device)	I_F	18/36	A	$T_c = 25\text{ }^\circ\text{C}$	
		9/18		$T_c = 135\text{ }^\circ\text{C}$	
		5/10		$T_c = 157\text{ }^\circ\text{C}$	
Repetitive Peak Forward Surge Current	I_{FRM}	30*		$T_c = 25\text{ }^\circ\text{C}$, $t_p = 10\text{ ms}$, Half Sine Wave	
Non-Repetitive Peak Forward Surge Current	I_{FSM}	100*		$T_c = 25\text{ }^\circ\text{C}$, $t_p = 10\text{ }\mu\text{s}$, Pulse	
Power Dissipation (Per Leg/Device)	P_{tot}	138/276	W	$T_c = 25\text{ }^\circ\text{C}$	
		60/120		$T_c = 110\text{ }^\circ\text{C}$	
Operating Junction and Storage Temperature	T_J, T_{stg}	-55 to +175	$^\circ\text{C}$		

* Per Leg, ** Per Device



Electrical Characteristics (Per Leg)

Parameter	Symbol	Typ.	Max.	Unit	Test Conditions	Note
Forward Voltage	V_F	1.6	1.8	V	$I_F = 5 \text{ A}, T_J = 25^\circ\text{C}$	
		2.6	3.0		$I_F = 5 \text{ A}, T_J = 175^\circ\text{C}$	
Reverse Current	I_R	50	200	μA	$V_R = 1200 \text{ V}, T_J = 25^\circ\text{C}$	
		100	1000		$V_R = 1200 \text{ V}, T_J = 175^\circ\text{C}$	
Total Capacitive Charge	Q_C	28		nC	$V_R = 1200 \text{ V}, I_F = 5 \text{ A}$ $di/dt = 500 \text{ A}/\mu\text{s}$ $T_J = 25^\circ\text{C}$	
Total Capacitance	C	455		pF	$V_R = 0 \text{ V}, T_J = 25^\circ\text{C}, f = 1 \text{ MHz}$	
		45			$V_R = 200 \text{ V}, T_J = 25^\circ\text{C}, f = 1 \text{ MHz}$	
		33			$V_R = 400 \text{ V}, T_J = 25^\circ\text{C}, f = 1 \text{ MHz}$	

Note: This is a majority carrier diode, so there is no reverse recovery charge.

Thermal Characteristics

Parameter	Symbol	Typ.	Unit
Thermal Resistance from Junction to Case	$R_{\theta JC}$	1.08**	$^\circ\text{C}/\text{W}$
		0.54*	

** Per Leg, * Both Legs

Typical Performance (Per Leg)

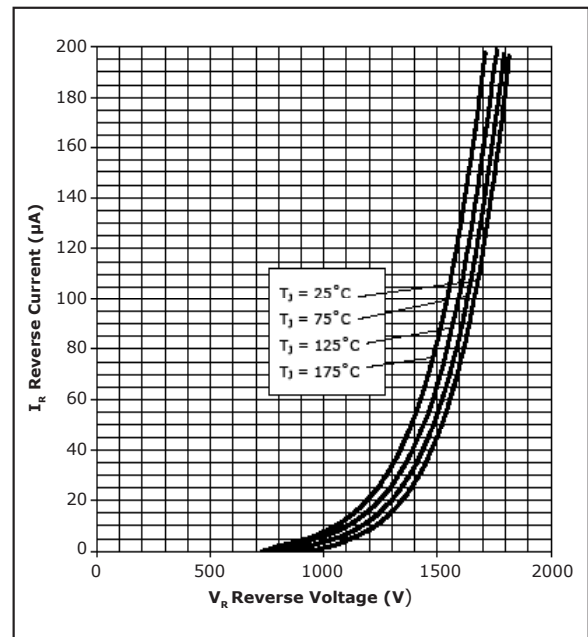
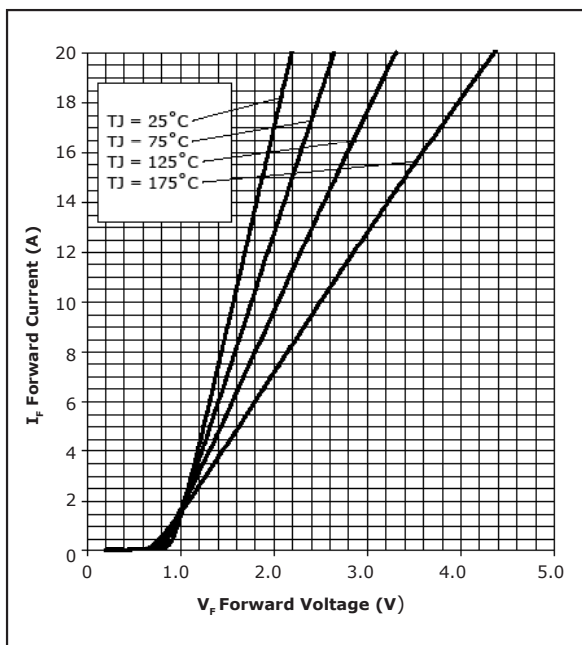

Typical Performance (Per Leg)

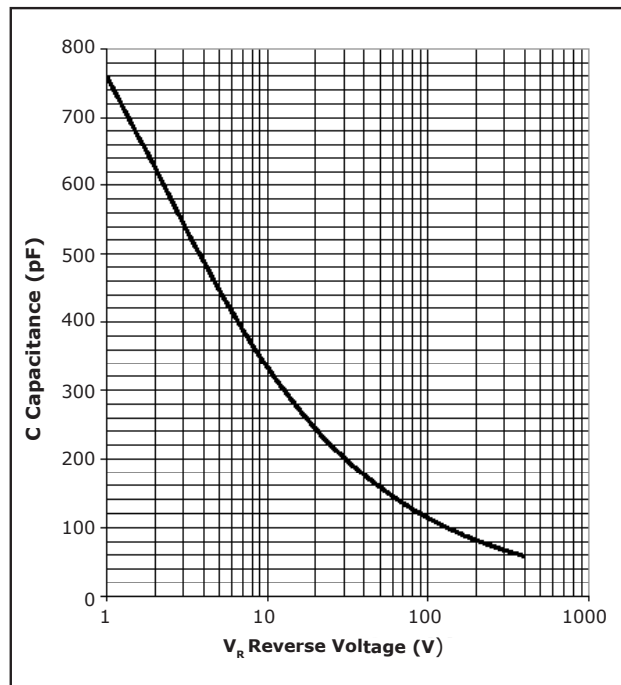
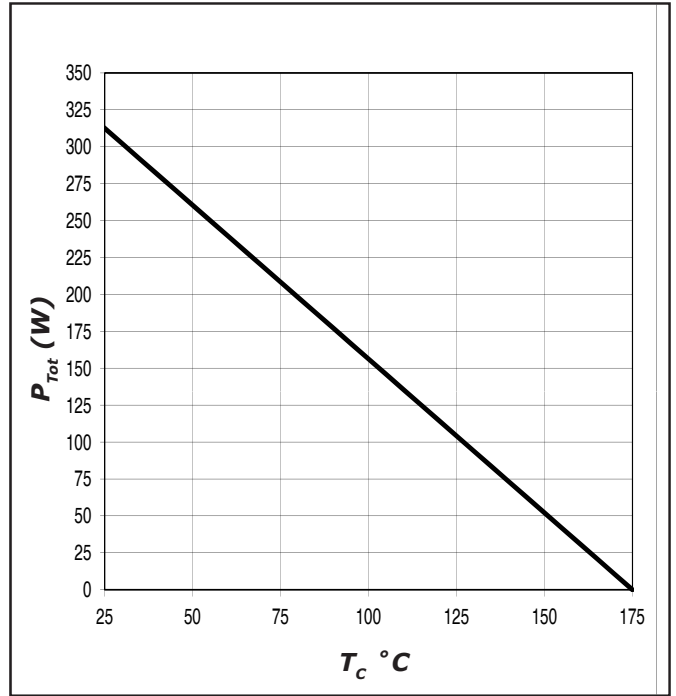
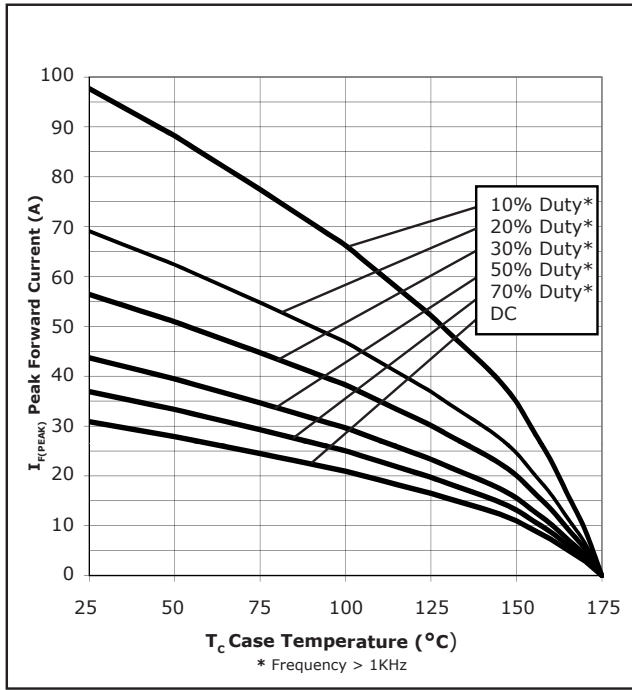
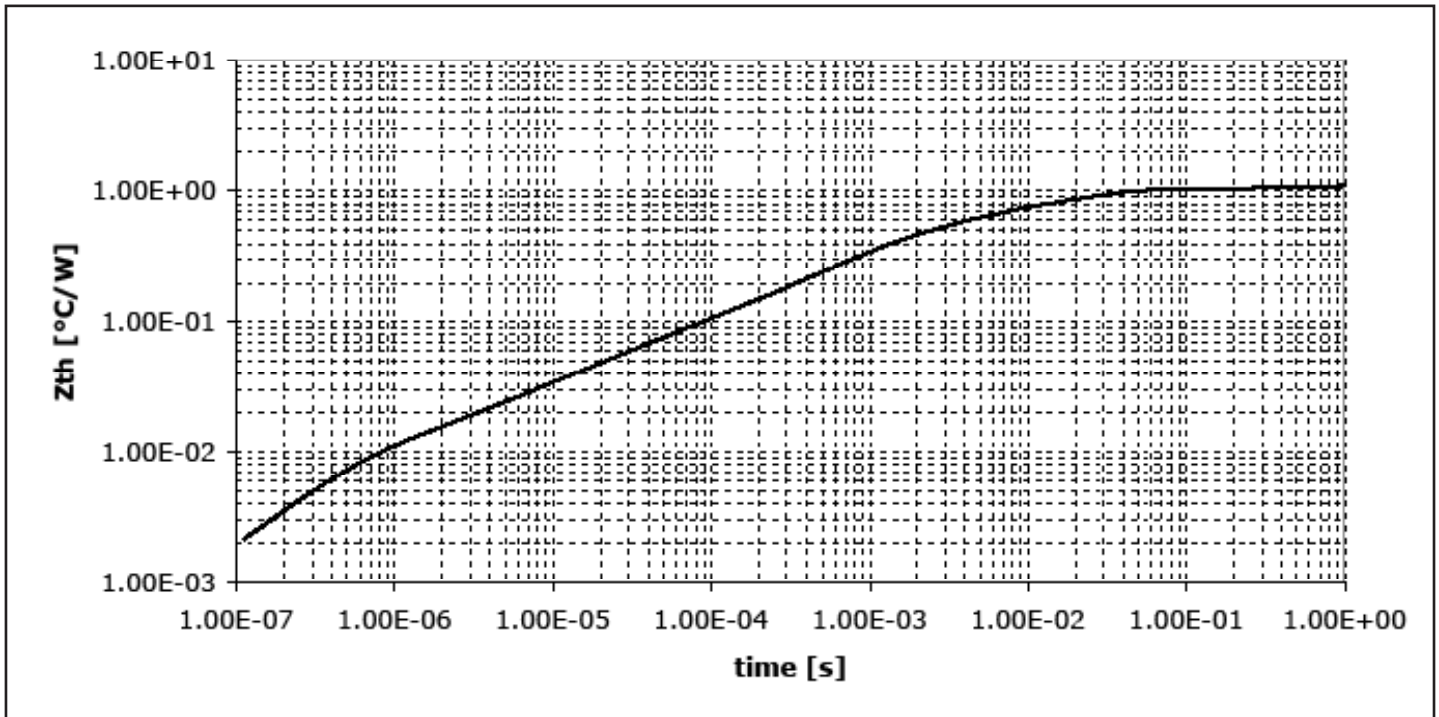

Figure 5. Capacitance vs. Reverse Voltage



Typical Performance



Package Dimensions

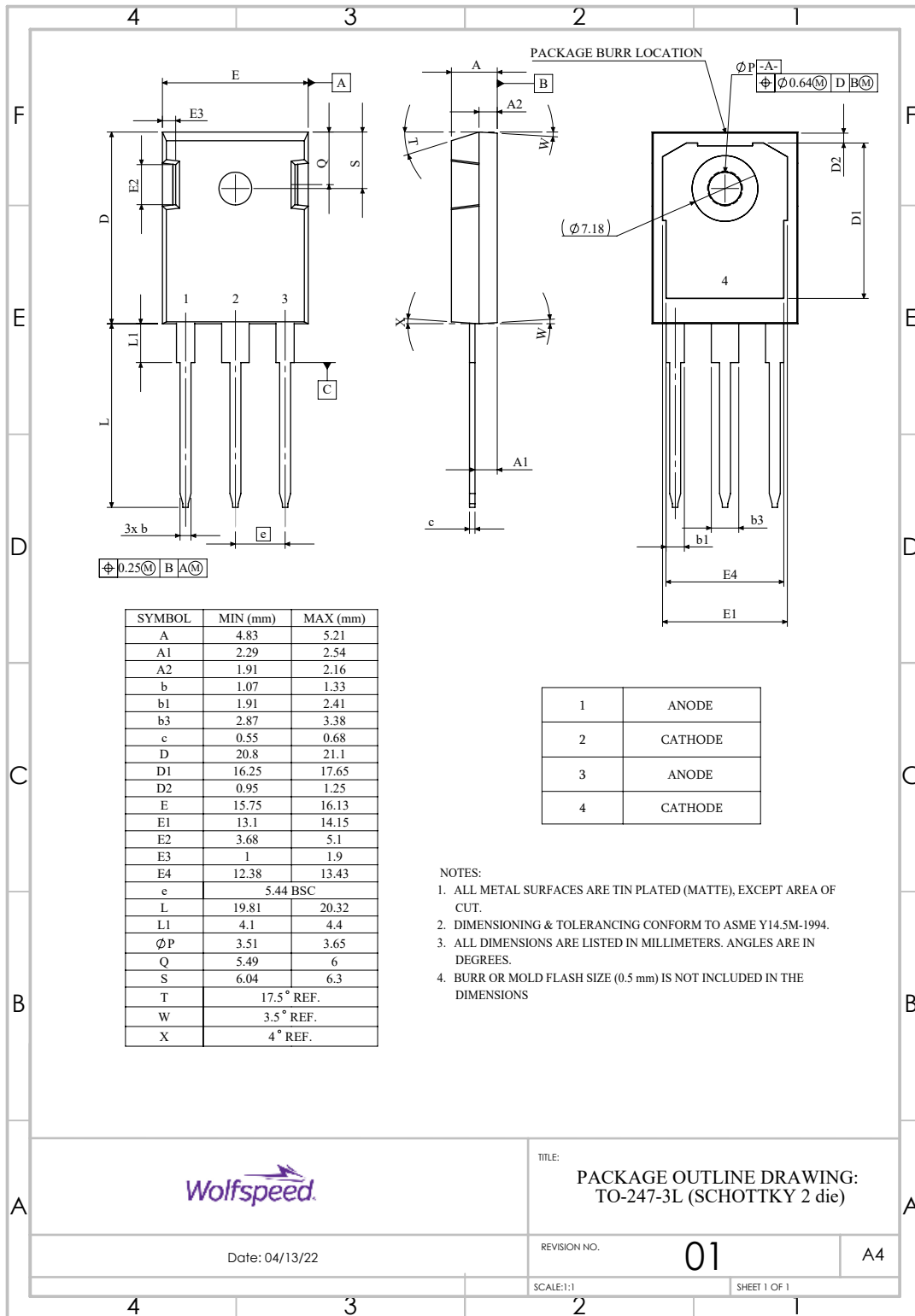



Recommended Solder Pad Layout

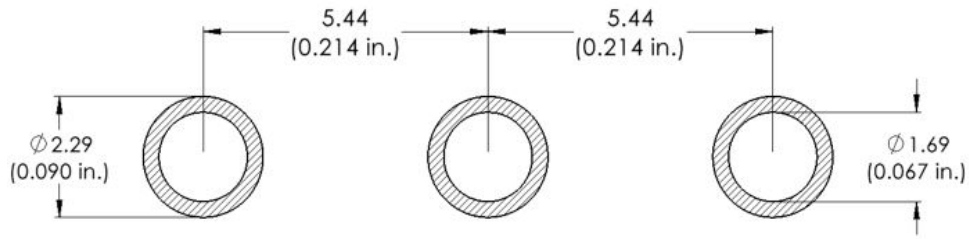

Part Number	Package	Marking
C2D10120D	TO-247-3	C2D10120



Revision History

Current Revision	Date of Release	Description of Changes
9	January-2024	Updated Wolfspeed branding, package drawing, and solder pad layout



Notes & Disclaimer

This document and the information contained herein are subject to change without notice. Any such change shall be evidenced by the publication of an updated version of this document by Wolfspeed. No communication from any employee or agent of Wolfspeed or any third party shall effect an amendment or modification of this document. No responsibility is assumed by Wolfspeed for any infringement of patents or other rights of third parties which may result from use of the information contained herein. No license is granted by implication or otherwise under any patent or patent rights of Wolfspeed.

Notwithstanding any application-specific information, guidance, assistance, or support that Wolfspeed may provide, the buyer of this product is solely responsible for determining the suitability of this product for the buyer's purposes, including without limitation for use in the applications identified in the next bullet point, and for the compliance of the buyers' products, including those that incorporate this product, with all applicable legal, regulatory, and safety-related requirements.

This product has not been designed or tested for use in, and is not intended for use in, applications in which failure of the product would reasonably be expected to cause death, personal injury, or property damage, including but not limited to equipment implanted into the human body, life-support machines, cardiac defibrillators, and similar emergency medical equipment, aircraft navigation, communication, and control systems, aircraft power and propulsion systems, air traffic control systems, and equipment used in the planning, construction, maintenance, or operation of nuclear facilities.

RoHS Compliance

The levels of RoHS restricted materials in this product are below the maximum concentration values (also referred to as the threshold limits) permitted for such substances, or are used in an exempted application, in accordance with EU Directive 2011/65/EC (RoHS2), as implemented January 2, 2013. RoHS Declarations for this product can be obtained from your Wolfspeed representative or from the Product Documentation sections of www.wolfspeed.com.

REACH Compliance

REACH substances of high concern (SVHCs) information is available for this product. Since the European Chemical Agency (ECHA) has published notice of their intent to frequently revise the SVHC listing for the foreseeable future, please contact your Wolfspeed representative to ensure you get the most up-to-date REACH SVHC Declaration. REACH banned substance information (REACH Article 67) is also available upon request.

Contact info:

4600 Silicon Drive
Durham, NC 27703 USA
Tel: +1.919.313.5300
www.wolfspeed.com/power